

Council on Dairy Cattle Breeding

Auditing Procedures for Meter Centers and Technicians

*Effective January 1, 2018
Version 18.0*

The purpose of this manual is to ensure the accuracy and uniformity of all records included in the national *Genetic Evaluation Program*.

Auditing of Meter Centers

<i>Meter Center Audits and Certification</i>	<i>Page 2</i>
<i>Centering Period Months for Meter Centers – Even Years</i>	<i>Page 3</i>
<i>Centering Period Months for Meter Centers – Odd Years</i>	<i>Page 4</i>
<i>Auditing of Calibration Check Equipment</i>	<i>Page 5</i>

Auditing of Meter Technicians

<i>Meter Technician Audits and Certification</i>	<i>Page 6</i>
<i>Auditing of Calibration Check Documentation</i>	<i>Page 7</i>
<i>Auditing of the Standard Water Test Procedure</i>	<i>Page 8</i>
<i>Auditing of the Fast-Flow Water Test Procedure</i>	<i>Page 9</i>
<i>Auditing of the Dual-Meter Water Test Procedure</i>	<i>Page 10</i>
<i>Auditing of the Weight Test Procedure</i>	<i>Page 11</i>

Appendices and References

<i>Description of the Standard Water Test Method</i>	<i>Page 12</i>
<i>Illustration of the Standard Water Test Rig</i>	<i>Page 14</i>
<i>Description of the Fast-Flow Water Test Method</i>	<i>Page 15</i>
<i>Illustration of the Fast-Flow Water Test Rig</i>	<i>Page 17</i>
<i>Description of the Dual-Meter Water Test Method</i>	<i>Page 18</i>
<i>Illustration of the Dual-Meter Water Test Rig</i>	<i>Page 20</i>
<i>Description of the Weight Test Method</i>	<i>Page 21</i>

Meter Center Audits and Certification

Meter Center Setup and Conditional Certification

To ensure that meter center equipment is properly installed and configured, the auditor may authorize qualified persons to assist in the design and construction of meter centers and allow them to issue a conditional certification. If applicable, a list of those persons will be available from the auditor.

Initial Certification Audits

Before achieving initial certification, meter centers must submit to an on-site audit and demonstrate compliance with all aspects of this manual, the *General Auditing Guidelines*, and with the *Code of Ethics* and *Uniform Data Collection Procedures*.

Audits

Once certification has been established, meter centers will be subject to a biennial, on-site audit in order to renew their certification. **At any time, additional audits may be called at auditor's discretion, or may be requested by the cooperating organization.**

Scheduling of Audits

Each meter center will be assigned a centering period month for on-site audits. Audits must be performed within 60 days of the centering period month.

Portable Meter Centers

In cases where service providers have a stationary meter center as their primary repair and calibration check center but also use a portable meter center for off-site calibration checks, the portable meter center is also be subject to separate, but concurrent on-site audit.

Period of Certification

The certification period will begin on the day of the on-site audit and extend through the last day of the 26th month following the centering period month. Meter centers failing to achieve certification renewal by the end of the 26th month will be classified as non-certified.

If failure to maintain standards is determined to have occurred by the auditor during the certification period, the service provider can be decertified prior to the end of the current certification period.

Decertification Procedures

Decertification will only be considered when the performance of a meter center has fallen below the minimum standards established by CDCB and the organization does not take prompt action to return to compliance within the time period specified by the auditor.

Decertification Appeals

For policies and procedures on decertification appeals, please refer to page 7 of the '*General Auditing Guidelines*' for a detailed protocol.

Centering Period Months for Meter Centers – Even Years

Meter Centers are subject to mandatory biennial, on-site audits. Below is a schedule of target months for the on-site audits scheduled to occur during even numbered years.

January

February

March Texas DHIA – Stephenville

April

May San Joaquin DHIA

June

July Mini-Cassia Calibration Center
..... Vanden Bosch Calibration Center

August

September Dairy One Cooperative Inc. – Portable
..... Dairy One Cooperative Inc. – Stationary

October

November Heart of America DHIA - Portable
..... Mid-South Dairy Records - Portable
..... Rocky Mountain DHIA
..... Tillamook DHIA
..... Washington State DHIA
..... Willamette DHIA

December Asociación Holstein de México

Centering Period Months for Meter Centers – Odd Years

Meter Centers are subject to mandatory biennial, on-site audits. Below is a schedule of target months for the on-site audits scheduled to occur during odd numbered years.

January	Minnesota DHIA
February	Arizona DHIA
.....	The Udder Tester, LLC
March	
April	DHI Cooperative Inc. – Stationary
.....	DHI Cooperative Inc. – Portable
May	Eastern New Mexico DHIA – Roswell
.....	Eastern New Mexico DHIA – Clovis
.....	Integrated Milk Testing Services
.....	Texas DHIA – Canyon
.....	Circle H Headquarters, LLC
June	NorthStar Cooperative Inc.– Michigan
July	
August	Lancaster DHIA
.....	DHIA West – Portable
.....	Kings County DHIA
.....	Central Counties DHIA
.....	Southern Counties DHIA
.....	Fresno DHIA
.....	Tulare DHIA
.....	Dairy Lab Services
September	
October	AgSource Cooperative Services/CRI – Portable - Dorchester
.....	AgSource Cooperative Services/CRI – Mega Test Rig and Calibration Rig - Menomonie
November	NorthStar Cooperative Inc.– Wisconsin
December	United Federation of DHIAs – Portable

Auditing of Calibration Check Equipment

Equipment Responsibility

The meter center is responsible for acquiring and maintaining all equipment and parts necessary for the proper calibration and repair of all types of weighing and sampling devices being serviced.

Equipment Required for Water Testing Methods

In order to operate any of the water test methods, the meter center must have the following equipment:

1. A manual from the manufacturer for each type of meter being checked for calibration,
2. A volumetric flask or scale accurate to within 1%,
3. A forty-pound capacity bucket or pail,
4. A vacuum source capable of providing 15 inches of vacuum,
5. A vacuum trap such as a weigh jar or bucket milker with a vacuum shut-off valve,
6. Two or three vacuum hoses, and
7. A leveled meter mounting bracket.
8. Effective January 1, 2012, all calibrations, regardless of test method used, must be performed using a manufacturer's approved wand or a closed (jar-to-jar) system approved by the auditor.

Equipment Required for the Standard Water Test Method

In addition to the general equipment listed above, the meter center must have a meter inlet vacuum hose equipped with (1) a restrictor orifice sized to produce a water flow of 8 pounds per minute and (2) an air admission orifice admitting ½-cubic foot per minute (CFM) of air measured at atmospheric pressure. The air admission orifice is to be fitted 24-36 inches from the meter inlet. The correct airflow can usually be provided by a hole produced by a #60 drill or by a 16 gauge hypodermic needle.

Equipment Required for the Fast-Flow Water Test Method

In addition to the general equipment listed above, the meter center must have a fast-flow rig capable of holding forty pounds of water and equipped with an upright tube having an orifice sized to produce the proper flow rate per minute.

Equipment Required for the Weight Test Method for Scales

In order to check the calibration of scales, the meter center must have access to a set of weights accurate to within 1% in the following increments:

1. If the weights are measured in pounds, they must be capable of determining increments of 10, 20, 30, 40, and 50 pounds.
2. If the weights are measured in kilograms, they must be capable of determining increments of 5, 10, 15, 20, and 25 kilograms.

Meter Technician Audits and Certification

Meter Technician Training and Conditional Certification

To ensure that meter technicians are properly trained in the repair and calibration check techniques of portable meters, the auditor may authorize qualified persons as meter technician trainers and allow them to issue a conditional certification. If applicable, a list of those persons will be available from the auditor.

Initial Certification Audits

Before achieving initial certification, meter technicians must submit to an on-site audit and demonstrate compliance with all aspects of this manual, the *General Auditing Guidelines*, and with the *Code of Ethics* and *Uniform Data Collection Procedures*.

Continuing Education of Meter Technicians

Each meter technician is required to attend a Meter Technician Training School approved by the auditor at least once every five years to retain certification.

Calibration Check Demonstrations

During an on-site audit, each meter technician will be expected to demonstrate proficiency with the meter calibration methods they use. The correct procedures are described within this manual.

Meter Model Certification

CDCB certification for meter technicians will be meter model specific. When new meter models are introduced, it will be the responsibility of the meter technician to receive factory training for that model prior to checking the new model for calibration.

Period of Certification

The certification period will begin on the day of the on-site audit and extend for 26 months. Meter technicians failing to achieve certification renewal by the end of the 26th month will be classified as non-certified.

If failure to maintain standards is determined to have occurred by the auditor during the certification period, the service provider can be decertified prior to the end of the current certification period.

Certification of Authorized Trainers

Persons authorized by the auditor as meter technician trainers will not be subject to on-site audits of meter calibration check procedures.

Decertification Procedures

Decertification will only be considered when the performance of a meter technician has fallen below the minimum standards established by CDCB and the person does not take prompt action to return to compliance within the time period specified by the auditor.

Decertification Appeals

For policies and procedures on decertification appeals, please refer to page 7 of the 'General Auditing Guidelines' for a detailed protocol.

Auditing of Calibration Check Documentation

Calibration Check Documentation

The meter technician must provide complete documentation to the meter owner for each portable meter or scale checked for calibration.

This documentation may be in the form of a computerized spreadsheet, manual listing, or other organized system and must include a report summarizing the number of meters checked and:

1. The make, model, and unique identification number of the meter or scale,
2. The owner of the meter or scale,
3. The meter technician's name,
4. The date of calibration check,
5. The preliminary calibration check reading, and
6. The actual calibration check readings.

Calibration Check Readings

The meter technician must record the actual calibration check readings in the reported documentation. The readings must correspond to the meter flask or scale graduations.

Calibration Check Tags or Markings

The meter technician must mark each portable meter or scale with a tag, sticker, engraving, or other marker indicating the calibration year and meter center or technician performing the calibration check prior to returning the meter to the owner.

Calibration of Repaired Meters and Scales

The meter technician must check the calibration of all portable meters and scales receiving repairs that may have affected accuracy before returning them to active service.

Auditing of the Standard Water Test Procedure

Eligible Portable Meters

The meter technician must demonstrate knowledge of each of the meter models eligible for this calibration check method.

Vacuum System and Equipment Configuration

The meter technician must demonstrate a working knowledge of the meter center setup and Standard Water Test Method equipment.

All calibrations must be performed using a manufacturer's approved wand or a closed (jar-to-jar) system approved by the auditor.

Initial Water Measurement

The meter technician must demonstrate that the initial water measurement has been attained through the use of a volumetric flask or accurate scale. Weigh jars and Fast-Flow rigs are not considered accurate enough to determine initial water measurement.

On-going Water Measurement

The meter technician must demonstrate an approved method of maintaining the water volume throughout a series of meter calibration checks. Approved methods include the use of a working float pail or a digital scale capable of calibration to 1%.

Flow Rates

The meter technician must demonstrate an understanding of the flow rates required for the Standard Water Test Method.

Acceptable Readings and Minimum Number of Calibration Checks Required

The meter technician must demonstrate an understanding of the acceptable calibration check results and the minimum number of times a meter must be checked for calibration.

Auditing of the Fast-Flow Water Test Procedure

Eligible Portable Meters

The meter technician must demonstrate knowledge of each of the meter models eligible for this calibration check method.

Vacuum System and Equipment Configuration

The meter technician must demonstrate a working knowledge of the meter center setup and Fast-Flow Water Test Method equipment.

Effective January 1, 2012, all calibrations must be performed using a manufacturer's approved wand.

Initial Water Measurement

The meter technician must demonstrate that the initial water measurement has been attained through the use of a volumetric flask or accurate scale. Weigh jars and Fast-Flow rigs are not considered accurate enough to determine initial water measurement.

On-going Water Measurement

The meter technician must demonstrate an approved method of maintaining the water volume throughout a series of meter calibration checks. Approved methods include the use of a working float pail or a digital scale capable of calibration to 1%.

Flow Rates

The meter technician must demonstrate an understanding of the flow rates required for the Fast-Flow Water Test Method.

Acceptable Readings and Minimum Number of Calibration Checks Required

The meter technician must demonstrate an understanding of the acceptable calibration check results and the minimum number of times a meter must be checked for calibration.

Auditing of the Dual-Meter Water Test Procedure

Eligible Portable Meters

The meter technician must demonstrate knowledge of each of the meter models eligible for this calibration check method.

Vacuum System and Equipment Configuration

The meter technician must demonstrate a working knowledge of the meter center setup and Dual-Meter Water Test Method equipment.

Effective January 1, 2012, all calibrations must be performed using a manufacturer's approved wand or a closed (jar-to-jar) system approved by the auditor.

Initial Water Measurement

The meter technician must demonstrate that the initial water measurement has been attained through the use of a volumetric flask or accurate scale. Weigh jars and Fast-Flow rigs are not considered accurate enough to determine initial water measurement.

On-going Water Measurement

The meter technician must demonstrate an approved method of maintaining the water volume throughout a series of meter calibration checks. Approved methods include the use of a working float pail or a digital scale capable of calibration to 1%.

Flow Rates

The meter technician must demonstrate an understanding of the flow rates required for the Dual-Meter Water Test Method.

Acceptable Readings and Minimum Number of Calibration Checks Required

The meter technician must demonstrate an understanding of the acceptable calibration check results and the minimum number of times a meter must be checked for calibration.

Auditing of the Weight Test Procedure

Weight Check Range

The meter technician must demonstrate an understanding of the range of weights required for scale calibration checks.

Scale Operation

The meter technician must demonstrate a working knowledge of the scale operation and adjustment procedures.

Acceptable Results

The meter technician must demonstrate an understanding of the acceptable calibration check results.

Description of the Standard Water Test Method

Eligible Portable Meters

The Standard Water Test Method may be used to calibrate the following brands and models of portable meters:

1. Foss Milko-Scope models
2. Waikato MK 5 models
3. Waikato SpeedSampler models
4. Tru-Test Auto Sampler models
5. Tru-Test Economy models
6. Tru-Test Ezi-Test models
7. Tru-Test Farmer models
8. Tru-Test Pull-Out models

Calibration Check Procedure

In order to properly conduct a calibration check using the Standard Water Test Method, the following procedure must be performed:

1. Using a volumetric flask or accurate scale, exactly 16.0 liters, 16.0 kg, 4.23 gallons, or 35.3 pounds of water should be placed in the forty-pound capacity pail.
2. The portable meter to be tested should be placed in the leveled bracket.

The suction hose containing the restrictor and air admission orifices should be connected to the portable meter inlet with the air admission orifice at least 24 inches from the portable meter inlet. The other end of the suction hose should be placed in the forty-pound capacity pail. Effective January 1, 2012, all calibrations must be performed using a manufacturer's approved wand or a closed (jar-to-jar) system approved by the auditor.

3. The hose from the vacuum source should be connected to the vacuum trap and the hose from the vacuum trap should be connected to the portable meter outlet.
4. The vacuum source should be turned on and must provide 15 inches of vacuum.
5. The vacuum trap valve should be opened and the water should be drawn into the portable meter inlet at a rate of 8-pounds per minute and air should be drawn into the air admission orifice at the rate of ½-CFM.
6. The water and air mixture should pass through the portable meter and the water should be captured in the vacuum trap.
7. The lower meniscus water level should be read on the portable meter and recorded as the calibration check reading.
8. The water remaining in the portable meter should be released into the vacuum trap and the vacuum trap valve should be turned off.

9. The water should be transferred from the vacuum trap into the forty-pound capacity pail and the steps 6-10 should be repeated as necessary.

Acceptable Readings and Minimum Number of Calibration Checks Required

For Foss, Waikato, and Tru-Test meters, the following guidelines should be used for determining the relative accuracy and number of calibration checks required to meet the CDCB specifications:

1. Meter readings between 35.7 and 37.1 lbs are within the 2% tolerance range and are considered accurate. No additional calibration checks are required to meet the CDCB guidelines.
2. Meter readings between 35.3 – 35.6 lbs OR 37.2 – 37.5 lbs are within the 2-3% tolerance range. A second calibration check is required to confirm their accuracy and meet the CDCB guidelines.
3. Meter readings <35.3 lbs or >37.5 lbs are not within the 3% tolerance and are not considered accurate enough for collecting milk weights. Portable meters must be repaired and checked for calibration again or taken out of service if they cannot consistently read within the 3% tolerance range.

Illustration of the Standard Water Test Rig

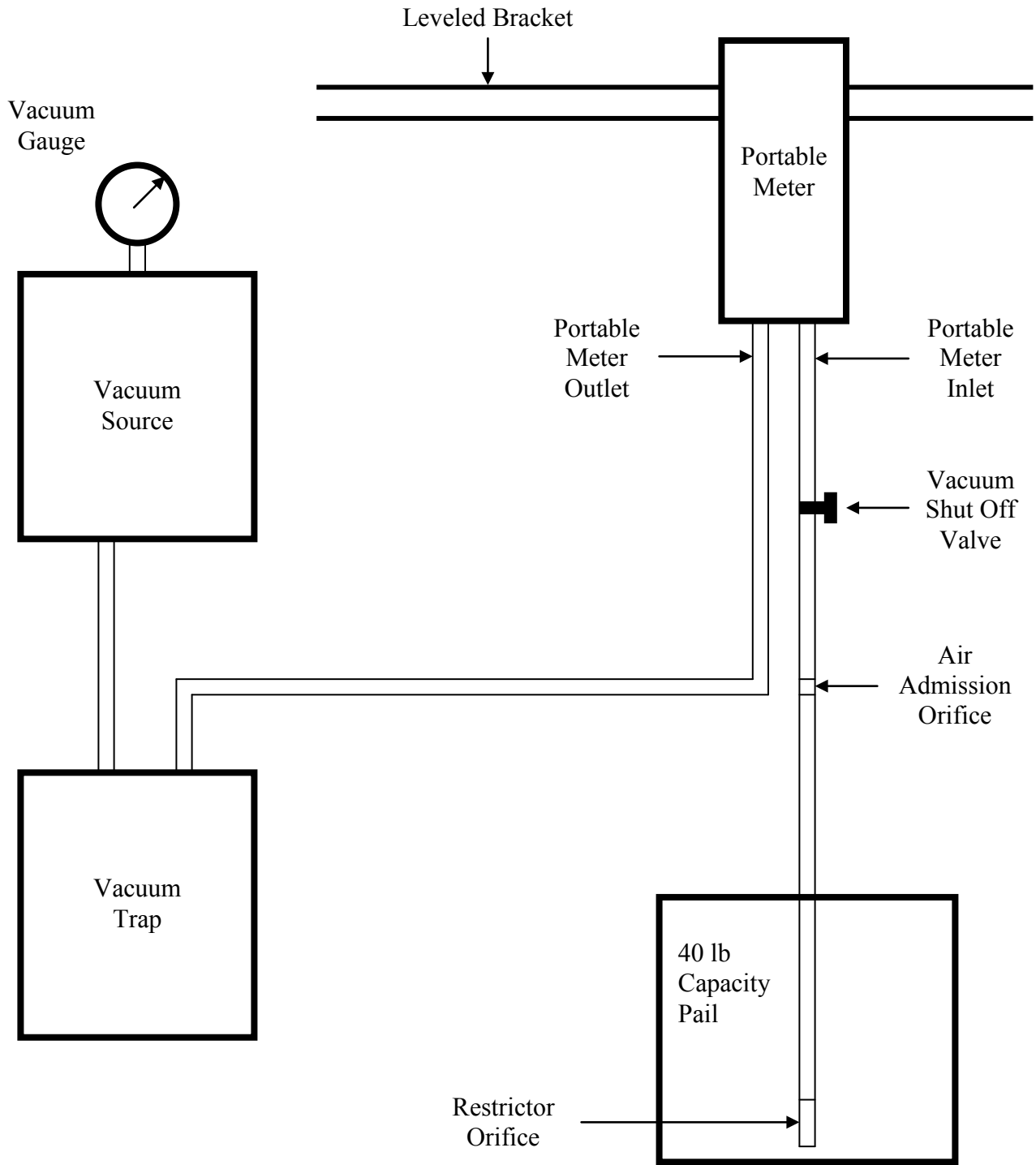

Description of the Fast-Flow Water Test Method

Eligible Portable Meters

The Fast-Flow Water Test Method may be used to calibrate the following brands and models of portable meters:

1. Foss Milko-Scope models
2. Tru-Test Auto Sampler models
3. Tru-Test Economy models
4. Tru-Test Ezi-Test models
5. Tru-Test Farmer models
6. Tru-Test Pull-Out models
7. Tru-Test Electronic Milk Meters (EMM)

Calibration Check Procedure

In order to properly conduct a calibration check using the Fast-Flow Water Test Method, the following procedure must be performed:

1. Using a volumetric flask or accurate scale, exactly 16.0 liters, 16.0 kg, 4.23 gallons, or 35.3 pounds of water should be placed in the fast-flow rig and the setting on the float indicator should be checked.

The portable meter to be tested should be placed in the leveled bracket. For Tru-Test meters, the flask to body seal ring should be 63 inches from the bottom opening of the water inlet tube.

2. A vacuum hose should be connected between the water inlet tube on the fast-flow rig and the portable meter inlet. This connection should be relatively straight. Effective January 1, 2012, all calibrations must be performed using a manufacturer's approved wand.
3. The hose from the vacuum source should be connected to the vacuum trap and the hose from the vacuum trap should be connected to the portable meter outlet.
4. The vacuum source should be turned on and should provide 15 inches of vacuum.
5. The valve on the water inlet tube of the fast-flow rig should be opened and the water should be drawn into the portable meter inlet. There should be no air inlet source.
 - A. For standard bore Tru-Test meters, the fast-flow rig should empty in 68 seconds.
 - B. For wide bore Tru-Test meters, the fast-flow rig should empty in 65 seconds.
6. The water should pass through the portable meter and should be captured in the vacuum trap.
7. The valve on the water inlet tube of the fast-flow rig should be closed.
8. The lower meniscus water level should be read on the portable meter and recorded as the calibration check reading.

9. The water remaining in the portable meter should be released into the vacuum trap.
10. The water should be transferred from the vacuum trap into the fast-flow rig and the steps 6-11 should be repeated as necessary.

Acceptable Readings and Minimum Number of Calibration Checks Required

For all eligible meters, the following guidelines should be used for determining the relative accuracy and number of calibration checks required to meet the CDCB specifications:

1. Meter readings between 35.7 and 37.1 lbs are within the 2% tolerance range and are considered accurate. No additional calibration checks are required to meet the CDCB guidelines.
2. Meter readings between 35.3 – 35.6 lbs OR 37.2 – 37.5 lbs are within the 2-3% tolerance range. A second calibration check is required to confirm their accuracy and meet the CDCB guidelines.
3. Meter readings <35.3 lbs or >37.5 lbs are not within the 3% tolerance and are not considered accurate enough for collecting milk weights. Portable meters must be repaired and checked for calibration again or taken out of service if they cannot consistently read within the 3% tolerance range.

Illustration of the Fast-Flow Water Test Rig

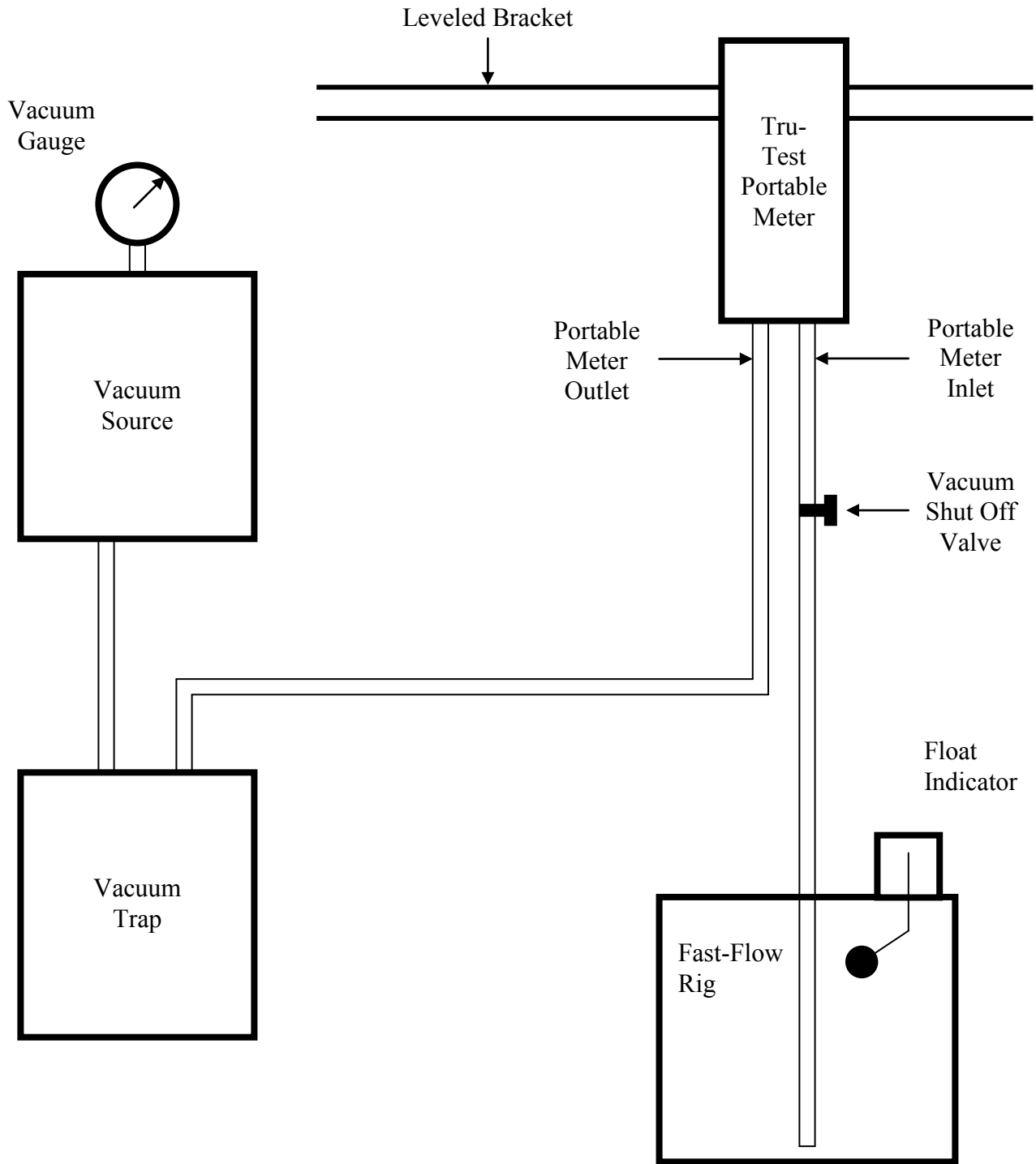

Description of the Dual-Meter Water Test Method

Eligible Portable Meters

The Dual-Meter Water Test Method may be used to calibrate the following brands and models of portable meters:

1. Foss Milko-Scope models
2. Waikato Mark 5 models
3. Waikato SpeedSampler models
4. Tru-Test Economy models
5. Tru-Test Ezi-Test models
6. Tru-Test Farmer models

Calibration Check Procedure

In order to properly conduct a calibration check using the Dual-Meter Water Test Method, the following procedure must be performed:

1. Using a volumetric flask or accurate scale, exactly 16.0 liters, 16.0 kg, 4.23 gallons, or 35.3 pounds of water should be placed in the forty-pound capacity pail.
2. The two portable meters to be tested should be placed in the leveled brackets. For this procedure, they will be referred to as meters X and Y.
3. The suction hose containing the restrictor and air admission orifices should be connected to the inlet of portable meter X with the air admission orifice approximately 24 inches from the portable meter inlet. Effective January 1, 2012, all calibrations must be performed using a manufacturer's approved wand or a closed (jar-to-jar) system approved by the auditor.
4. The other end of the suction hose should be placed in the forty-pound capacity pail.
5. A hose should be connected from the outlet of portable meter X to the inlet of portable meter Y.
6. The hose from the vacuum source should be connected to the vacuum trap.
7. The hose from the vacuum trap should be connected to the outlet of portable meter Y.
8. The vacuum source should be turned on and should provide 15 inches of vacuum.
9. The vacuum trap valve should be opened and the water should be drawn into the inlet of portable meter X at a rate of 8-pounds per minute and air should be drawn into the air admission orifice at the rate of ½-CFM.
10. The water and air mixture should pass through portable meter X and continue through portable meter Y.
11. After passing through portable meter Y, the water should be captured in the vacuum trap.

12. The lower meniscus water level should be read on portable meter X and recorded as the calibration check reading.
13. The water remaining in portable meter X should be released into portable meter Y, including any water captured in the sampler.
14. The lower meniscus water level should be read on portable meter Y and recorded as the preliminary calibration check reading.
15. The water remaining in portable meter Y should be released into the vacuum trap and the vacuum trap valve should be turned off.
16. The water should be transferred from the vacuum trap into the forty-pound capacity pail and the steps 9-16 should be repeated as necessary.

Acceptable Readings and Minimum Number of Calibration Checks Required

For Foss, Waikato, and Tru-Test meters, the following guidelines should be used for determining the relative accuracy and number of calibration checks required to meet the CDCB specifications:

1. Meter readings between 35.7 and 37.1 lbs are within the 2% tolerance range and are considered accurate. No additional calibration checks are required to meet the CDCB guidelines.
2. Meter readings between 35.3 – 35.6 lbs OR 37.2 – 37.5 lbs are within the 2-3% tolerance range. A second calibration check is required to confirm their accuracy and meet the CDCB guidelines.
3. Meter readings <35.3 lbs or >37.5 lbs are not within the 3% tolerance and are not considered accurate enough for collecting milk weights. Portable meters must be repaired and checked for calibration again or taken out of service if they cannot consistently read within the 3% tolerance range.

Illustration of the Dual-Meter Water Test Rig

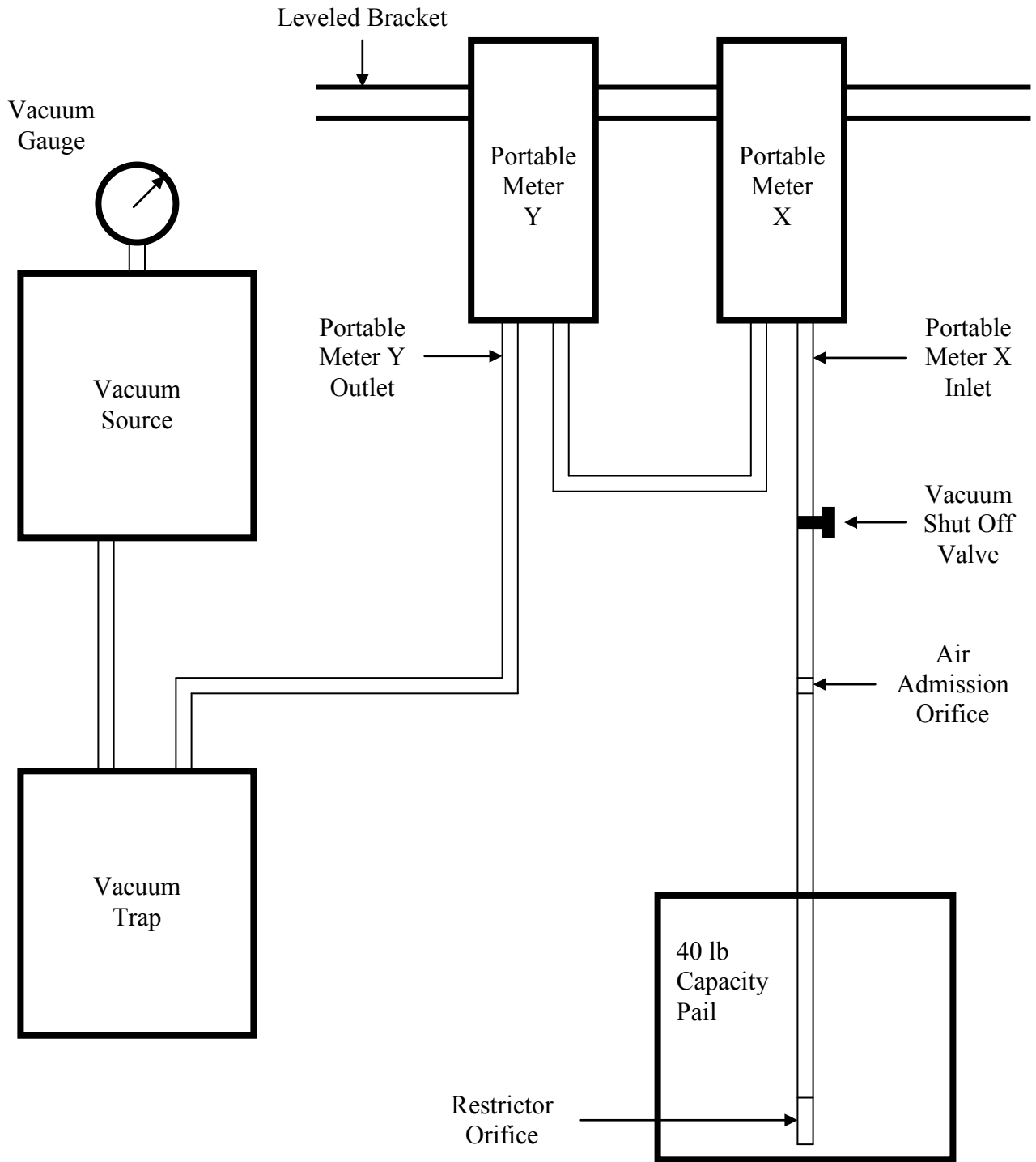

Description of the Weight Test Method

Calibration Check Procedure

In order to properly conduct a calibration check using the Weight Test Method, the following procedure must be performed:

1. With the hanging scale hooked on a secure structure or the stationary scale supported on a flat surface, a bucket or pail should be hung or placed on the scale and the pointer should be set to zero.
2. The check weights should be added to the bucket or pail in the increments listed on the chart below.
3. The readings on the scale should be recorded and compared to the following chart.
 - A. If the readings fall within the expected ranges, the scale calibration should be considered within acceptable tolerances.
 - B. If the readings are outside of the expected ranges, the scale calibration should be considered out of tolerance and the scale should be taken out of service, repaired, or replaced.

Acceptable Readings for Calibration Checks

The following chart illustrates the acceptable readings for calibration checks. All readings should fall within 3% of the known weight.

Check Weight	Acceptable Range In Pounds
10 lb	9.7 - 10.3
20 lb	19.4 - 20.6
30 lb	29.1 - 30.9
40 lb	38.8 – 41.2
50 lb	48.5 – 51.5