

# Milk Sampler



## Installation and Operation Instructions

The Dairy Equipment Div.  
of DEC International, Inc.  
PO Box 8050  
Madison, VM 53708  
608-222-3484

### Table of Contents

Introduction .....	1
1. Preparation .....	1
2. Installation .....	2
2.1 Installing the Sampler Mounting Bracket .....	2
2.2 Installing the Sampler and Hoses .....	2
3. Operation .....	3
4. Maintenance .....	4

The information within this instruction packet is intended to aid both the dealer and the dairyman in the installation and operation of the milk sampler. These instructions replace the first version of literature no. 9P-419.

The Table of Contents lists the sections of this packet in the order in which they should be read and procedures should be carried out. And special *warnings*, *cautions*, and *notes* have been provided throughout this packet to aid the dealer and dairyman in following instructions and making decisions. Read these special notes and all instructions carefully before installing and using the product to ensure proper installation and use.

Proper installation and maintenance of all system parts are essential for the dairyman to obtain maximum benefit from Bou-Matic products.

*The dairyman is responsible for maintaining and monitoring the equipment to ensure that it functions properly.*

### Introduction

The Bou-Matic® Milk Sampler is a device which allows the operator to obtain a sample of milk, for analysis of its composition, from a milking cow before the milk enters the milk line. The sampler is intended for use with Bou-Matic milk meter models “M” and “M+” only, as its accuracy cannot be assured with other models. (See Section 3 for details on the sampler’s operation.) The milk sampler is efficient, because it collects equal amounts of milk throughout the entire milking (regulated by an orifice in its cover) to provide a sample that is proportional in composition to the full amount of milk produced by the cow and thoroughly mixes the milk sample. The sampler is convenient, because it returns any milk that is collected but not removed for analysis to the milk line.

### 1 Preparation

To make sure that you have everything you need to install the milk sampler, take all the items out of the packing boxes, and check to see that the items correspond to the list which follows.

Description	Quantity
Milk Sampler .....	1
Mounting Bracket .....	1
Hose, large, formed .....	1
Hose, small .....	1
Lubricant .....	1 tube

In the unlikely event that something is missing, contact the Bou-Matic Customer Service Department immediately.

When installing the sampler, the dealer should be equipped with standard installation tools. All nonstandard tools will be so indicated in the appropriate sections of this packet.

## 2 Installation

### Note

All installation work noted in section 2.1 will be done by the dealer.

### 2.1 Installing the Sampler Mounting Bracket

One sampler mounting bracket must be permanently mounted to each milk meter in a parlor. (Additional sampler brackets can be ordered separately for meters that will share samplers.)

To install the milk sampler, use the following procedure:

1. **Determine which side of the meter the sampler will be mounted to. Then, mount the sampler bracket and meter bracket to the curb, using the fasteners used to mount the meter bracket.** (See Figure 1.) The slots in the sampler bracket should align with those in the meter bracket. Do not tighten the fasteners yet.

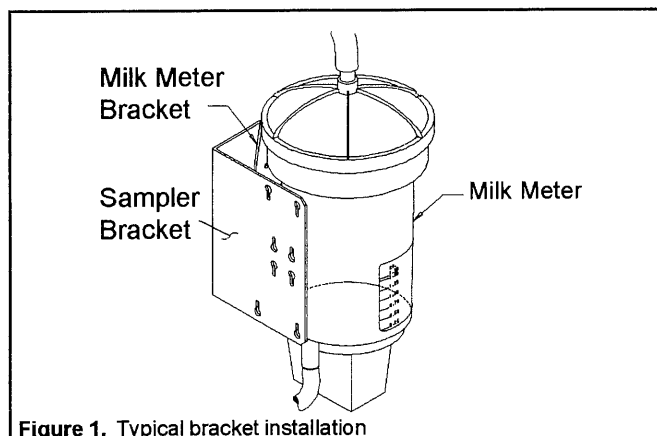

2. **Ensure that the meter housing is level.**

This is done by removing the meter housing cover and placing a level on top of the meter in two different directions (at right angles to each other, as shown in Figure 2). Tighten all fasteners. Then, reassemble the cover onto the housing, making sure that the gasket around the meter rim seats properly.

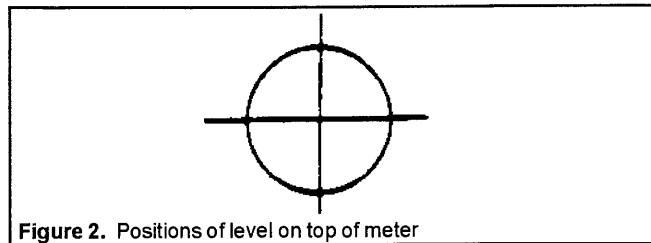

Figure 2. Positions of level on top of meter

### 2.2 Installing the Sampler and Hoses

Before each use, sanitize the sampler and all hoses associated with it, according to the instructions in Section 4. Then, install the sampler, as shown in Figure 3 and explained below:

1. **Connect one end of the small hose to the small tubulation on the sampler's cover—the other end to the tubulation at the bottom of the sampler.**
2. **Position the sampler on the sampler bracket such that the sampler's four screw heads, when inserted and lowered into the keyhole slots on the bracket, lock in place.**
3. **Disconnect the 5/8" hose from the milk outlet on the meter, and connect it to the large, horizontal tubulation on the sampler cover.**
4. **Connect one end of the formed hose to the milk outlet on the meter—the other end to the vertical tubulation on the sampler's cover.**  
Warm the ends of the formed hose in hot water just before assembly to ease its installation.

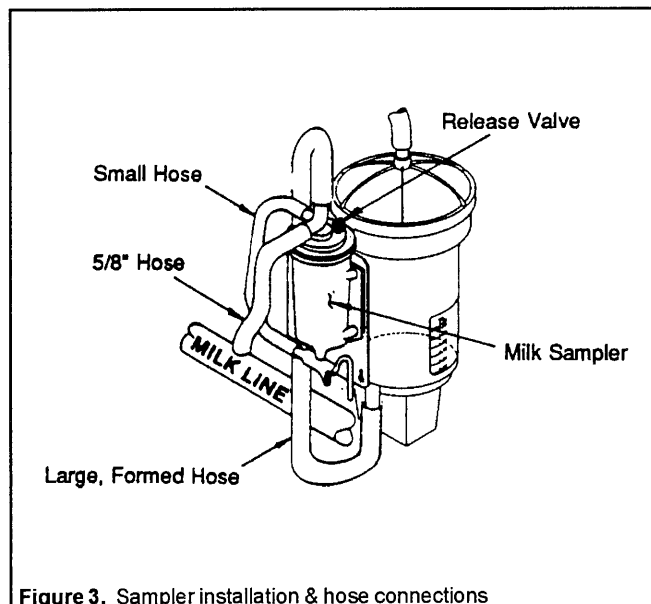

Figure 3. Sampler installation & hose connections

5. **Adjust the cover, as necessary, to align the hoses.**  
Loosen the band clamp around the sampler cover, and rotate the cover as necessary, ensuring that the gasket surfaces seat properly. Then, finger tighten the clamp.

### 3 Operation

#### Note

The milk sampler is intended for occasional use only. Remove it, except when needed.

#### Caution

- To prevent damage to the milk sampler, when moving the valve handle in any direction, use care to support the sampler.
- To prevent damage to the drain valve (because it may seize up during storage), before using the sampler, press the valve handle in, then pull it out.

To use the sampler, use the following procedure:

1. **Close the drain valve.**  
To close the valve, position the loop of the valve handle upward and against the stop as shown in Figure 4.

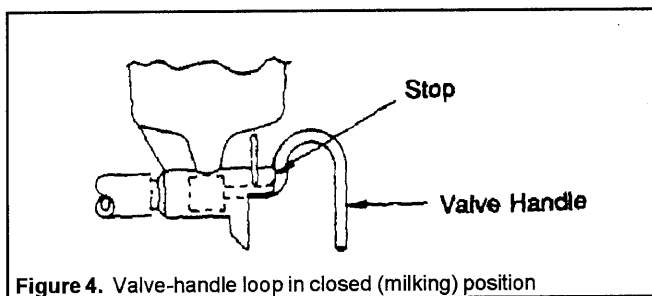

2. **Ensure that the release valve, on top of the sampler cover (see Figure 3), is seated properly.**
3. **Milk the cow and allow the sampler to collect milk until the cow is milked out and the milk meter is completely empty.**

4. **Mix the milk inside the sampler for 20 seconds.**  
To mix the milk, rotate the valve-handle loop downward and fully press the valve in, as shown in Figure 5. Air will enter the sampler and create a turbulence that will mix the milk.

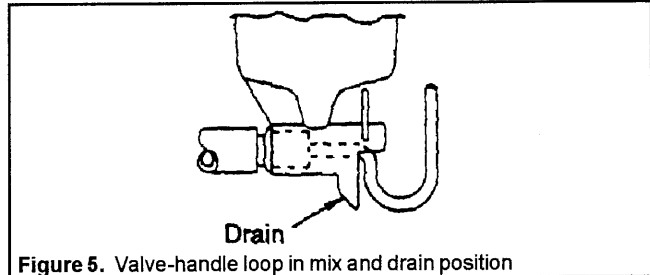

6. **Collect the milk sample from the sampler.**  
Hold a sample bag or bottle under the sampler drain, and raise the release valve until you've collected the desired amount of milk.
7. **Empty any remaining milk from the sampler into the milk line.**  
Pull the valve handle out as far as possible, as shown in Figure 6, and raise the release valve.

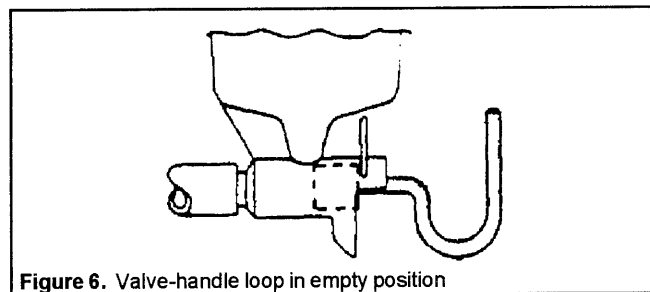

## 4 Maintenance

---

### Before Each Use

Before each use, disassemble and hand sanitize the milk sampler and its associated hoses. Then, reassemble the sampler. Before disassembling the sampler, review the caution notes in Section 3 for instructions on proper handling of the sampler and valve handle. To remove the valve, first remove the hair pin, then pull out the valve. When reassembling the gasket and cover to the sampler, ensure that the gasket surfaces seat properly and that the clamp is snug but not overly tight.

### Caution

Certain materials contain ingredients which will attack the milk sampler's plastic parts. Do not expose the plastic parts to any of the following:

- Acetone
- Aniline
- Benzyl alcohol, Ethanol, Isopropanol, Methanol
- Formaldehyde
- Hydrochloric acid
- Hydrogen peroxide
- Nitric acid
- Sulfuric acid

In addition, use of cleaners other than those recommended by Bou-Matic and excessive concentrations of those that are recommended is not advised.

Use of nonrecommended chemicals on the sampler and damages to the sampler, resulting from improper cleaning, will nullify any warranty covering those parts.

### After Each Use

Disassemble the sampler and hand wash it, using the procedure specified above under "Before Each Use." After cleaning the sampler, lubricate the valve O-rings (with the lubricant supplied) to prevent the valve from seizing during storage. Then, reassemble and store the sampler in a clean place.

### Periodically

Periodically inspect the O-rings, gasket, and release valve for signs of cracking or pitting.

### Yearly

Replace all rubber parts yearly.

# BOU-MATIC 2100M & 2700M DETACHER/METER OPERATORS INSTRUCTIONS



DAIRY EQUIPMENT COMPANY  
Division of DEC International, Inc.  
P.O. Box 8050 • Madison, WI 53708

## TABLE OF CONTENTS

I. Introduction	1
II. System Overview	2
III. Operation	3
A. Attach	3
B. Milking	4
C. Detach	4
D. Manual Mode	4
E. Special Operation	4
F. Washing	5
IV. Adjustments	6
A. Addresses	6
B. Takeoff Settings	6
C. Dump Delay	8
D. Units of Measurement	8
V. Maintenance	8
VI. Checkout and Troubleshooting	9

## I. INTRODUCTION

Bou-Matic offers two models of air-operated detacher/meters: the 2700M and 2100M. The 2700M and 2100M differ mainly in the way the retract arm works. The unique features of each are explained below:

### A. MODEL 2700M

1. The four-link arm holds the claw in position under the cow and retracts automatically.
2. Claw and hose supports keep the milking unit in position throughout milking without restricting cow movement.

### B. MODEL 2100M

1. The chain retract mechanism makes this detacher compact.
2. The (optional) hose support arm swings into position when you push the Attach/Detach button. It maintains proper milker position and retracts as milker is removed.

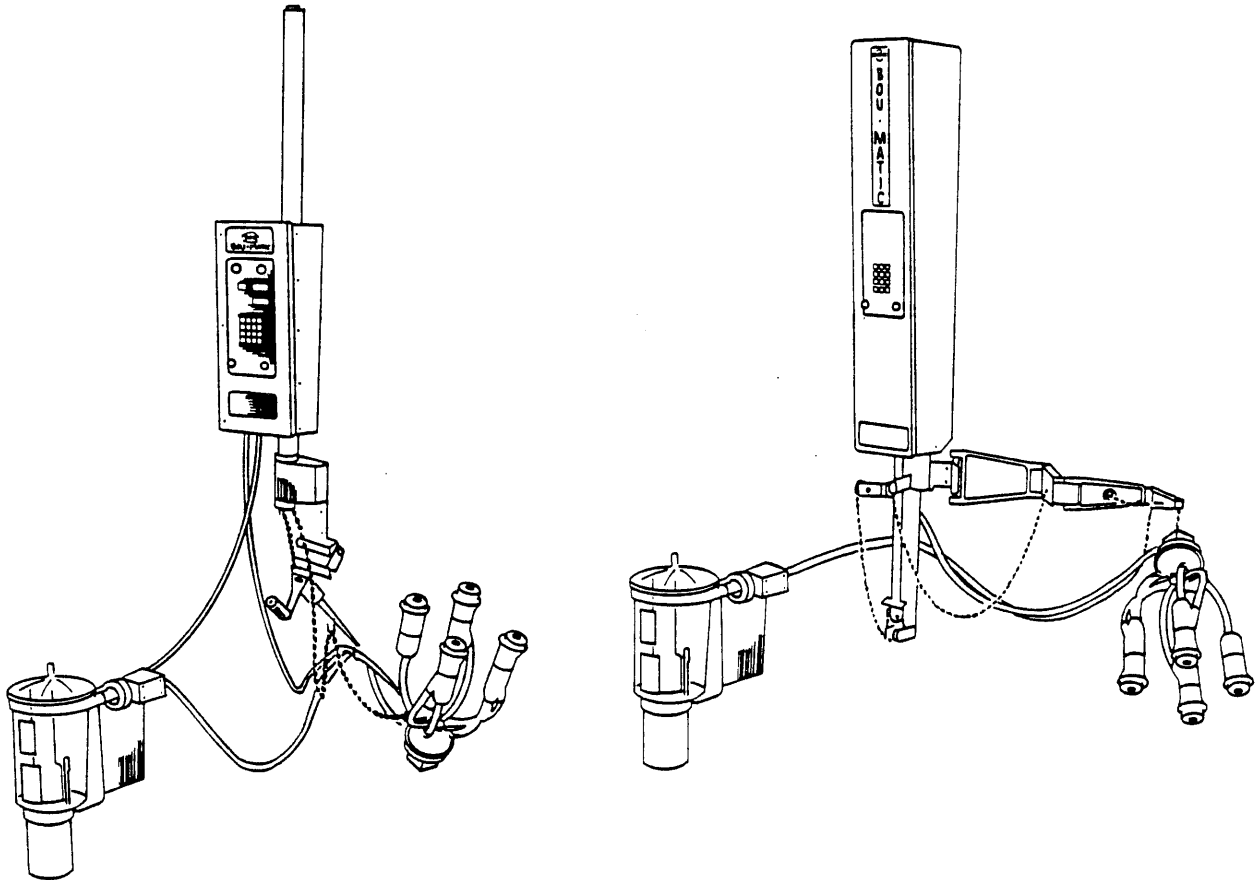

Figure 1. 2100M and 2700M Detachers

## II. SYSTEM OVERVIEW

The 2100M AND 2700M Detacher consist of three major assemblies: the electronic control and display, the meter assembly and the detach mechanism. The following sections explain operation of each assembly.

### A. ELECTRONIC CONTROL AND DISPLAY

1. The ATTACH/DETACH button is for releasing the milking unit to attach it to the cow and for manual takeoff of the milking unit.
2. The AUTOMATIC/MANUAL button is for selecting either manual or automatic mode.
3. The Manual light is ON when the detacher is in manual takeoff mode instead of automatic mode.
4. The No Milk light is ON when the cow is giving milk at a rate less than your selected flow rate, usually .7 pounds per minute.
5. The display shows the CODE for the information displayed and the TIME the milking unit has been on the cow, or it shows the COW NUMBER and her PRODUCTION.
6. The keyboard is used to select special functions described later.

### B. MODEL 'M' MILK METER OPERATION

The meter accurately measures production and calculates flow rate to determine takeoff. As milk and air enter the meter from the claw, they are separated. To maintain stable vacuum level, the meter bypasses air through the center of the rotor. Milk flows around the main chamber and down the inside walls to minimize foaming. See Figure 3.

As the milk level rises within the main chamber, the rotor chambers located over the filling trough also fill, as the liquid seeks the same level within the rotor chamber as in the main chamber. See Figure 4.

The float level controls the rotor drive motor. When milk lifts the float, the rotor turns and each chamber dumps a measured amount of milk as it moves over the outlet port. This continues until the milk level lowers the float. See Figure 5.

With the small, slotted wheel located on the rotor drive shaft and a magnetic sensor, the meter actually counts how many rotor chambers pass over the outlet port. This allows the meter control to determine how much milk has passed through the meter. See Figure 6.

### C. DETACH MECHANISM OPERATION

Once the electronics sense that milk flow has ceased, vacuum is shut off to the claw and compressed air activates the mechanism to detach the unit.

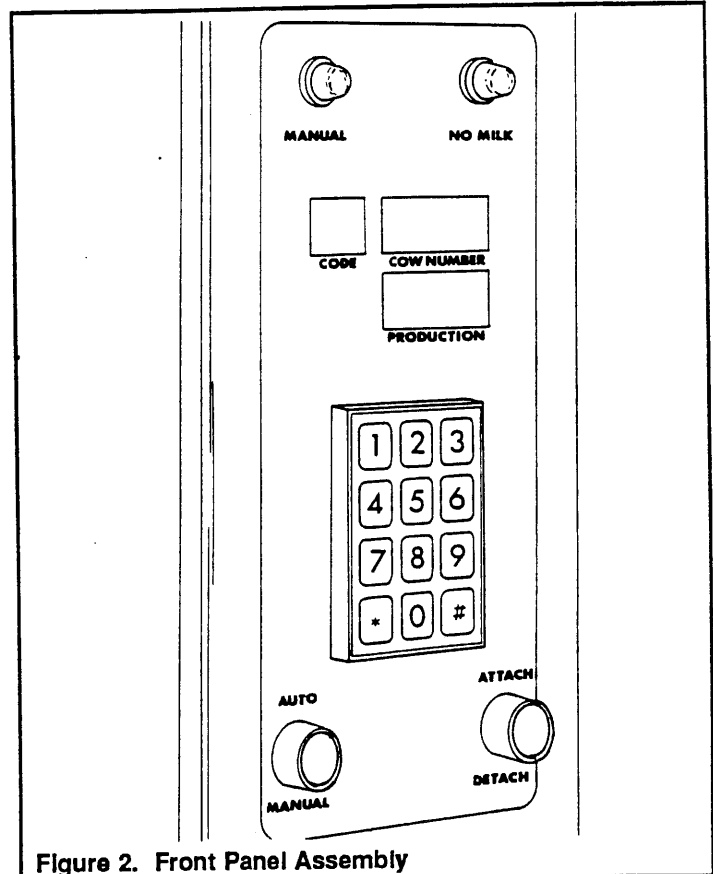

Figure 2. Front Panel Assembly

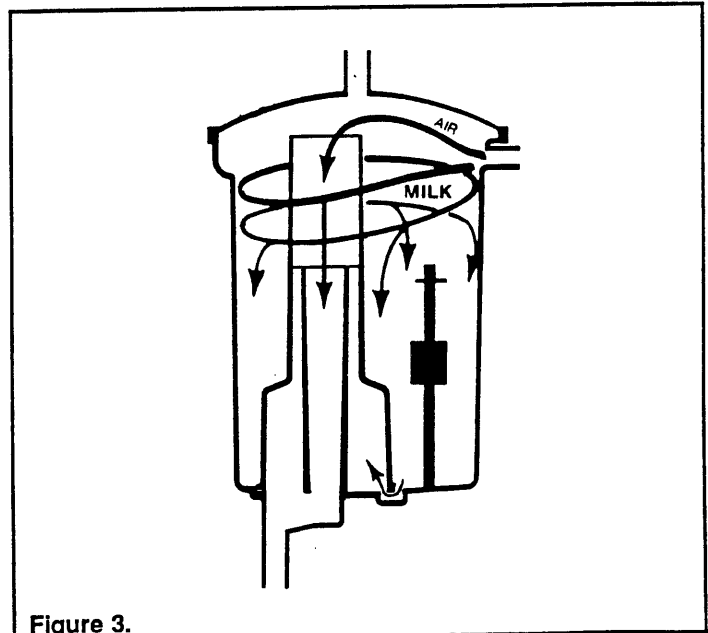

Figure 3.

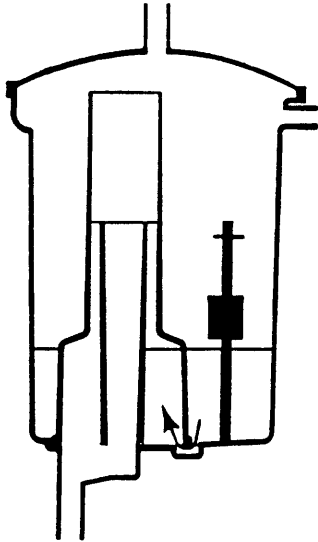

Figure 4.

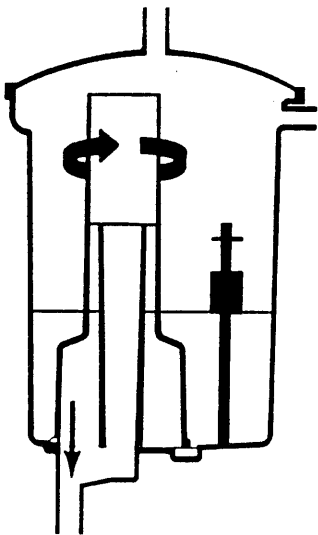

Figure 5.

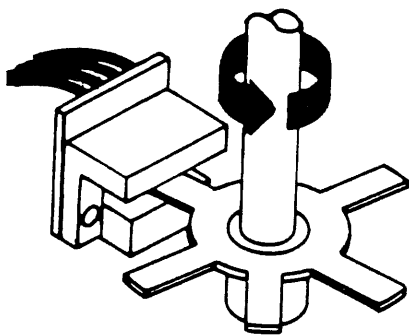

Figure 6.

### III. OPERATION

#### A. ATTACHING UNIT

##### 1. 2700M

- a. Be sure the Manual Light is OFF. If it is ON, press the Auto/Manual button to turn it OFF.
- b. Press the ATTACH/DETACH button. This will release the claw and arm and open the milk valve. The display will read:

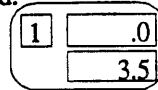

- c. Lower the unit, pushing arm out under the cow and unfold.
- d. Attach teat cups. The best sequence is: far front, far rear, near rear, near front.
- e. Adjust arm's height so there is slack in the chain holding the claw. The claw's weight must be totally supported by the cow. Figure 7.
- f. Operator must monitor slack in chain to assure proper milking until unit is removed.
- g. Be sure that arm is positioned under cow so that claw and hoses are parallel with the cow's centerline.

SLACK →

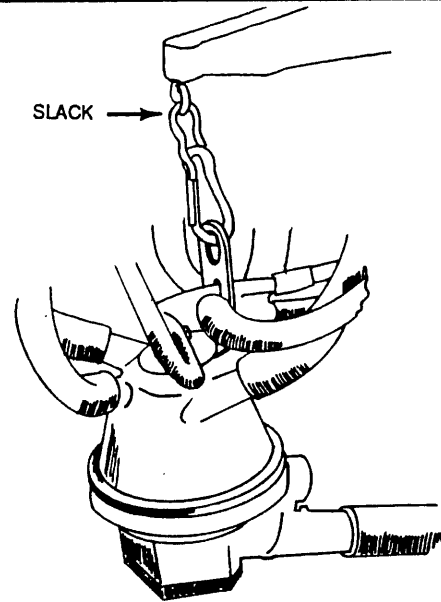

Figure 7. Slack in Chain When Attaching 2700

Correct

Incorrect

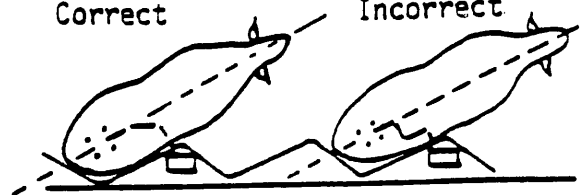
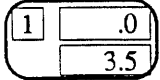

Figure 8. 2700 Arm Position (From top of cow)

## 2. 2100M

- Be sure the Manual Light is OFF. If it is ON, press the AUTO/MANUAL button to turn it OFF.
- Holding claw in your hand, press the ATTACH/DETACH button. This will release the claw from the unit and open the milk valve. The display will read:



- Attach teat cups.
- Adjust hoses in arm loop so claw is positioned properly on cow.
- Lay chain in the chain hook on the arm. This keeps chain clear of the cow's leg.

## B. MILKING

### NOTE:

The milking unit will not detach during the first 2.2 minutes so the cow has time to let her milk down and the meter can fill to 3.5 pounds. The 2.2 minutes may vary slightly with takeoff delay setting.

- After the cow has given more than 3.5 pounds, the rotor starts to turn and the display begins to count.
- When the cow starts giving milk at a rate greater .7 lbs/min (based on the takeoff setting), the No Milk light goes off.
- When the cow starts giving less than 0.7 lbs/min, the No Milk light turns ON.

## C. DETACH

When milking is complete (based on the End of Milk delay selected), the unit retracts in the following sequence:

- Time stops counting.
- Milk valve closes.
- 2700M: Air cylinder retracts making arm lift and fold to remove claw.  
2100M: Air cylinder retracts pulling on chain to remove claw and retract hose support arm.
- The number 25 appears in the "Code" section of the display.

If the unit was attached for more than three minutes, the No Milk light will be on continuously after detach. 30 seconds after detach, rotor turns to dump the remaining 3.5 pounds left in the meter. This milk, since it was counted at the beginning, is not counted now.

### Early Detach

If the unit was attached in automatic mode for less than three minutes, the No Milk light blinks after detach, indicating an early detach. In this case, check the cow.

### Foam in Meter

Foam in the meter often settles enough to raise the float and

start the motor after detach. This production is counted until the dump cycle begins.

## D. MANUAL MODE

Putting the unit in Manual Mode overrides detacher activation by milk sensing, and it will not retract unless the operator pushes the ATTACH/DETACH button. You must be careful to prevent overmilking when operating in manual mode.

- Attach the claw as described above.
- Press the AUTO/MANUAL button, so the Manual Light is ON.
- Press the ATTACH/DETACH button when cow is done. This will cause the milking unit to detach. The unit will automatically return to the automatic mode after the meter has dumped.
- Production is displayed as in the automatic mode.

## E. SPECIAL OPERATION

### 1. Reattaching to the Same Cow

When a detacher is detached, and you want to reattach to the same cow, first press the AUTOMATIC/MANUAL button (so the manual light turns ON), then press ATTACH/DETACH button. To avoid a possible premature detach after reattaching, leave the detacher in manual mode until the No Milk light goes out.

This sequence keeps the previous production and time and adds any new production and time to the previous amounts. If you reattach after the 3.5 pounds of milk has been dumped from the meter, that 3.5 pounds is lost from the total on the display.

### 2. Detacher Display Operation

You can operate the display at any time. You can view the information stored in the detacher by entering the following commands at the detacher.

Press	Display	Explanation
0 #		Cow Number (if entered) Production
1 #		Time (Sec.) Production
2 #		End of Milk Flow Rate Time Delay

### NOTE:

The display will go blank and lights will turn off if no button is pushed for 23 minutes. The display and lights will return when any button is pushed.



## F. WASHING

**WARNING:**  
Do not use high pressure spray nozzles to clean the electronic meter control. Water may enter the enclosure, damaging the electronic components.

Coverage, concentration and temperature are three ingredients needed to properly clean a milking system. With a meter system, wash sink capacity must allow for an extra 3/4 gallons of water per meter installed. Follow these recommendations:

### 1. Adequate Coverage

The installer must adjust the air injectors so the water slugs are long enough to get proper water coverage, but far enough apart so the milk pump can keep up. After the meter fills, slugs of water must raise the water level above the top of the float tube. If it doesn't, readjust the air injector.

### 2. Concentration

Use Bou-Matic chlorinated pipeline cleaner for washing and Bou-Matic Acid Cleaner for an acidified rinse to properly clean the milking system. The amounts of chemicals needed to clean the milking system must be determined by the dealer after completing a water analysis. The dealer should fill out a cleaning chart at installation.

**WARNING:**  
Numerous materials have ingredients which attack the plastic of the meter. Use of cleaners other than those recommended is at the owner's risk. Do not expose the meter to the following:

1. Fly sprays
2. "Super" glues
3. Gasoline, turpentine, brake fluids and ethers
4. Refrigerants
5. Loctite and similar compounds
6. Phosphate
7. Bou-Matic Manual Cleaner
8. Phenols
9. Alcohol, ethanol, isopropanol
10. Excessive concentrations of cleaners

### 3. Temperatures

The water rinse, acid rinse and sanitize cycles should be at 110°F and the detergent wash temperature should be between 155-165°F at the beginning of the wash cycle. Most localities require a minimum of ten minutes for the wash cycle. The water temperature at the end of the wash cycle must not be below 110°F.

## 4. Washing Instructions

To get unit ready for washing:

- a. Put each detacher in the ATTACH and MANUAL mode. The panel indicates this condition by displaying a "1" and lighting the Manual Light.
- b. Attach claw to the jetter and open the jetter wash valve.
- c. Open the washline valve above each meter to let water enter the meters. The meter is now ready for the washing cycle.
- d. When the detacher is in the washing cycle and after seven minutes of inactivity, the meter "recognizes" it has been washed and the rotor will turn to dump any remaining water from the meter.
- e. After washing and 23 minutes of face plate inactivity, the display and lights will automatically power down. The Manual and No Milk lights will glow slightly. The lights and display will resume operation when any button is pushed.
- f. Use a sponge and mild detergent to clean outside of detacher cabinet.

**IMPORTANT:**  
DO NOT TURN OFF POWER. This keeps Detacher warm and dry to extend the life of electronic components.

## IV. ADJUSTMENTS

### NOTE:

If detacher electronics do not have silver colored chassis, refer to Literature Number 9P-513 for adjustments instructions.

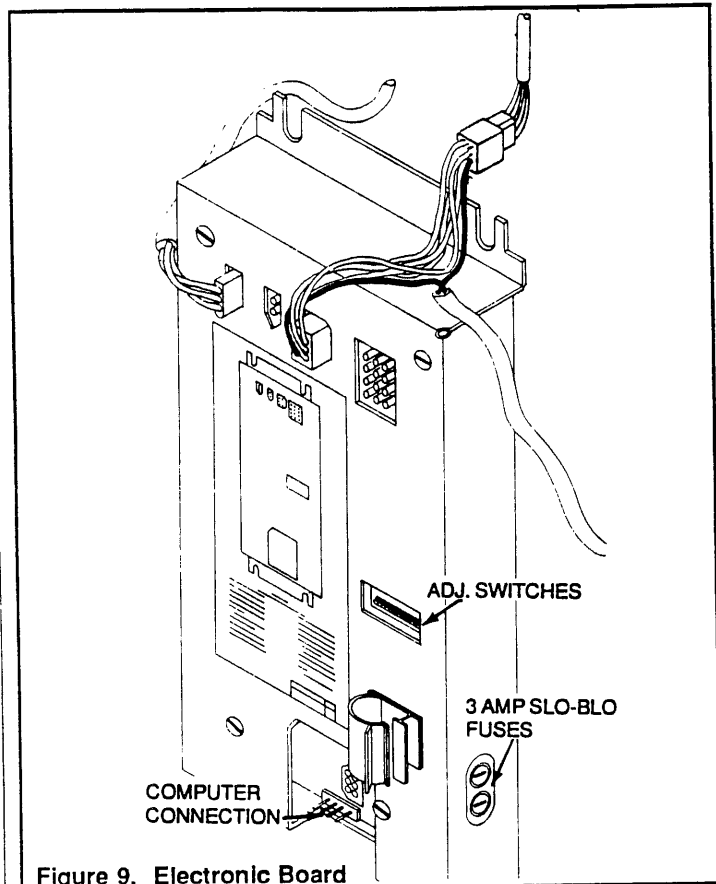

Figure 9. Electronic Board

### A. ADDRESS

Use switches 1 to 6 to set an address for each detacher when using an Agri-comp computer. See Agri-comp instruction manual for further information.

### B. TAKEOFF SETTINGS

#### 1. System Without an Agri-comp Computer

##### a. Switch Settable Delays

You can choose from three time delay settings (8, 13 and 22 seconds) by changing the switch settings on the switch bank located on the electronic board. See Figure 9. Units are preset at the factory for a 13 second delay and a flow rate of .7 lbs/min. (The flow rate can only be changed by individually programming each detacher as explained later.)

The delay time is the amount of time after the no-milk light comes on that the unit will detach. To check the setting, press

② #

on the detacher keyboard. The display will indicate the flow rate and delay as shown in the example. See Figure 10. Press

① #

to return to time and production display.

### NOTE:

By having switches 8 and 9 both off, takeoff settings can be set at values other than those permitted by use of switches. See Section c.

Table 1. Switch Settable Delays

Switch 8	Switch 9	Flow lbs/min	Delay seconds	Appr. Time* seconds
OFF	ON	.7	22	54
ON	OFF	.7	13	45
ON	ON	.7	8	40

\* Time from cessation of milk flow to beginning of claw removal.

\*\* Factory setting for parlor units.

#### b. Keyboard Entered Delays

Occasionally it may be necessary to adjust a takeoff setting for an individual cow. For such cases, you can program both flow rate and delays on the detacher keyboard. Keyboard entered delays and flow rates override preset switch settings. Enter delay and rate by pressing the following command sequence on the detacher keyboard. This setting is valid only for the current cow. Detacher will return to switch setting upon attach in automatic mode.

② \* (desired flow rate in .1 lbs/min) \* (delay rate in seconds) #

Table 2. Example Acceptable Programmable Takeoff Settings

Flow lbs/min	Delay Sec	Appr. Time* Sec
.7	22	54
.7	13	45
.7	8	40
.7	22	54
.7	13	45
.7	8	40
.7	22	54

\* Time from cessation of milk flow to beginning of claw removal.

Other settings can be entered, but have not been tested by DECO.

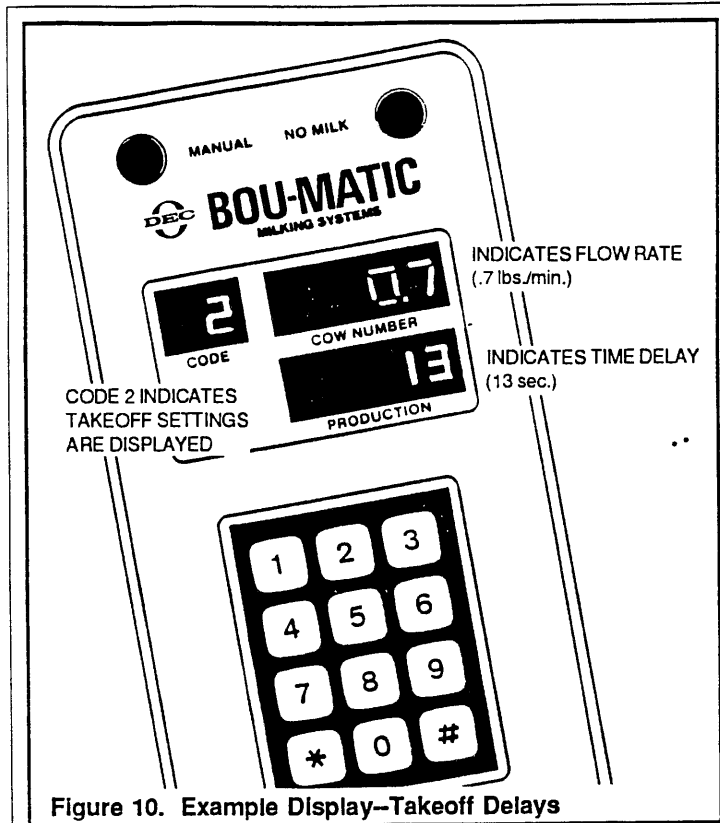

Figure 10. Example Display--Takeoff Delays

**EXAMPLE:**

You are using the detachers with the standard factory settings. However, you would like the unit automatically removed faster on one particular fast-milking cow. You want the setting to be .8 lbs/min and 5 second delay for this cow.

1. Attach the unit in automatic mode.
2. Press the following command sequence:  
 ② \* ⑧ \* ⑤ #
3. Change the display back to time and production by pressing:  
 ① #

The unit will automatically detach approximately 22 seconds after the claw empties. When attaching to the next cow in the automatic mode, the delay settings automatically revert back to the switch settings.

**c. Special Programming Capabilities**

In rare cases the entire parlor may require a different flow setting than the .7 lbs/min built into the electronics. For such cases, switches 8 and 9 must both be OFF.

This setting permits you to program the units from the detacher keyboard as explained earlier. However, the programmed setting will remain in the detacher memory for subsequent cows. The programmed setting will be followed until it is manually changed, the system experiences a power interruption or the detacher is reset.

**NOTE:**  
 If switches 8 and 9 are both OFF, the takeoff setting entered is used for all subsequent cows milked at that detacher until you enter another setting; reset the control or power is off more than one minute.

You must be cautious when using the detachers in this mode to make sure the correct delay settings are maintained in the detacher memory. Always check each detacher delay setting before milking. All detachers should have identical settings.

We recommend you install battery backups whenever detachers are used this way. Battery backups minimize intermittent power fluctuations which can cause detacher memory loss. If power is lost, battery backups will supply power to detachers and meters for up to one minute.

To enter a different takeoff setting, do the following at each detacher:

- (1) Press AUTOMATIC/MANUAL and ATTACH/DETACH buttons at the same time: release AUTOMATIC/MANUAL button first.
- (2) Press the following command sequence:  
 ② \* (desired flow rate in .1 lb/min) \* (delay time in seconds) #
- (3) Verify setting by pressing:  
 ② #
- (4) Change the display back to time and production by pressing:  
 ① #

**NOTE:**  
 In silver-colored chassis electronics, settings will return to .7 lb/min and 13 seconds after a power loss, even if switches 8 and 9 are both set to OFF. Reset the detacher after power is turned on to enter different take-off settings.

**2. Parlor System with Agri-comp**

The Agri-comp computer overrides all detacher switch settings. See the instruction manual for your Agri-comp computer to change from its default settings.

Takeoff settings can still be entered for individual cows after attaching to the cow by pressing the following command sequence:

- ② # (flow rate) \* (time) #

### C. DUMP DELAY

When a cow is finished milking, the 3.5 pounds left in the meter is automatically emptied. This keeps each cow's milk completely separated. This milk is not counted in production as it is dumped, because the 3.5 pounds is recorded at the beginning. The automatic emptying can be set to occur 30 seconds or immediately after detaching, depending on the position of switch 7.

Dump Delay (Sec)	Switch 7
30	ON
0	OFF

### D. UNITS OF MEASUREMENT

You can measure milk in either pounds or kilograms, depending on the position of switch 10.

Units of Measurement	Switch 10
Kgs	ON
Lbs	OFF

## VI. MAINTENANCE

### A. ONCE A WEEK:

1. Drain air compressor tank and airline moisture drop. Failing to do this will reduce the effective volume of a tank and shorten compressor life.
2. 2700M: Grease forward positioning cam once a week with a water-resistant grease. Failure to do this will cause the arm to retract with a jerk. See Figure 11.

### B. EVERY TWO WEEKS:

Check meter for cleanliness. Especially important is float and drain operation.

### C. EVERY THREE MONTHS:

1. Check rubber on meter rotor base. If torn, grooved or separated, replace rotor.
2. Lubricate the O-ring located under the meter spade drive with Bou-Matic O-ring grease.
3. Replace hose inside milk valve every three months or if it is partially collapsed.

### D. YEARLY: (or every 6000 cows milked)

In addition to the three month maintenance items, replace the following parts on a yearly basis:

- 1.O-ring under the meter spade drive
- 2.Meter check valve
- 3.Meter cover O-ring

### E. "MANUAL" AND "NO MILK" LIGHT BULBS

Be sure to use only Bou-Matic lamp bulbs for replacements. Electronic failures may result if other types are used.

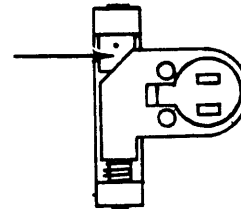
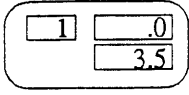
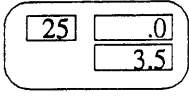

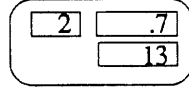

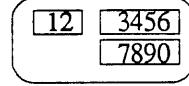

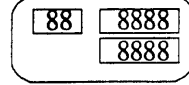

Figure 11. Grease Forward Positioning Cam Here

## VI. SYSTEM CHECKOUT

Follow the procedure below for each detacher to make sure it functions properly. The procedure assumes that standard factory settings have not been altered. If results shown are not obtained, consult your Bou-Matic Dealer.

Action:	Result:
1. Turn vacuum and power supply on.	1. Detacher should power up and retract.
2. Do a manual reset on each detacher by pressing the Auto/Manual and Attach/Detach buttons at the same time. Release the Auto/Manual button first.	2. After releasing buttons, display should read: 
3. Push Attach/Detach button to detach unit.	3. Display should read: 
4. Remove meter cover and rotor. Push Attach/Detach button to simulate attaching the unit.	4. Manual light OFF, No Milk light ON.
5. Wait 12 seconds after pushing Attach/Detach button and lift meter float until production begins recording.	5. No Milk light should go out, Production should advance.
6. Release float so that unit will detach before three minutes are up. (If detach is after three minutes, no milk light will be on steady.)	6. If no Production after 2.2 minutes, each detacher should automatically detach and No Milk light should flash. (Simulates early detach.) 30 seconds after detach, the meter motor should turn for approximately 30 seconds which simulates dumping any remaining milk.
7. Replace meter rotor and cover. Check each detacher takeoff delay by pushing: 	7. All detacher displays should read: 
8. Check retract speed of each detacher with inflations, shells and claws installed.	8. Units should not drag on floor.
9. Press Attach/Detach twice to check shutoff operation.	9. Vacuum to claw should shutoff just before retracting.
10. Water test each meter for accuracy. See Meter Water Test Instructions, Lit. No. 9P-341.	
11. Enter:  To clear the display, enter: 	11. Detacher display should read: 
12. Enter:  To clear the display, enter: 	12. Detacher display should read: 
13. Press Auto/Manual and Attach/Detach buttons several times.	13. The Manual and No Milk lights should alternate from very bright to dim.

# 2101M Detacher

## Installation and Operation Instructions

### Table of Contents

INTRODUCTION .....	1
1. GENERAL INFORMATION .....	2
1.1 Unpacking the Detachers .....	2
1.2 Evaluating the AC Power .....	3
1.3 Installing Lightning Protection Modules .....	3
2. INSTALLATION .....	3
2.1 Installing the Power Supply .....	3
2.2 Installing the Air System .....	4
2.3 Installing the Parlor Wash System .....	5
2.4 Installing the Detachers .....	5
2.4.1 Mounting the Detacher & Hose Support Arm .....	6
2.4.2 Mounting the Milk Meter .....	7
2.4.3 Connecting the Hoses .....	8
2.4.4 Connecting Power to the Detachers .....	8
2.4.5 Connecting Air to the Detachers .....	8
2.4.6 Making Mechanical Adjustments .....	9
2.4.6.1 Adjusting the Link Chain .....	9
2.4.6.2 Adjusting the Arm Stop Mechanism .....	9
2.4.6.3 Adjusting the Torsion Spring .....	9
2.4.6.4 Adjusting the Hose Support Arm .....	9
2.4.6.5 Adjusting the Takeoff Speed .....	10
2.4.6.6 Changing Detacher Address Settings .....	10
2.4.6.7 Changing the Takeoff & Flow Rate Settings .....	10
2.4.6.8 Changing the Dump Delay Setting .....	11
2.4.6.9 Changing the Unit of Measure .....	12
2.4.7 Checking Detacher Functions .....	12
3. TROUBLESHOOTING .....	14
4. PARTS REPLACEMENT .....	19
5. DETACHER SYSTEM OPERATION .....	21
5.1 Understanding the Detacher Assemblies .....	21
5.2 Understanding the Automatic & Manual Modes .....	22
5.3 Using the Keypad & Display .....	24
5.4 Using the Milking System .....	25
6. WASH SYSTEM OPERATION .....	25
6.1 Washing Milk Contact Surfaces .....	25
6.2 Washing Non-Milk Contact Surfaces .....	25
7. MAINTENANCE .....	26

### INTRODUCTION

The Bou-Matic® Model 2101M Detacher is an electronic control and detach mechanism, which monitors a cow's milk flow to determine when she is milked out, then gently removes the milking unit from the cow. In short, once attached to a cow, the milking unit will stay in place and continue milking as long as the detacher's milk meter measures a consistent milk flow rate. When the flow rate drops below the predetermined rate, the detacher starts a preset takeoff delay, which allows the cow to reestablish her milk flow if it temporarily paused. If she does not resume her milk flow before the delay time elapses, the

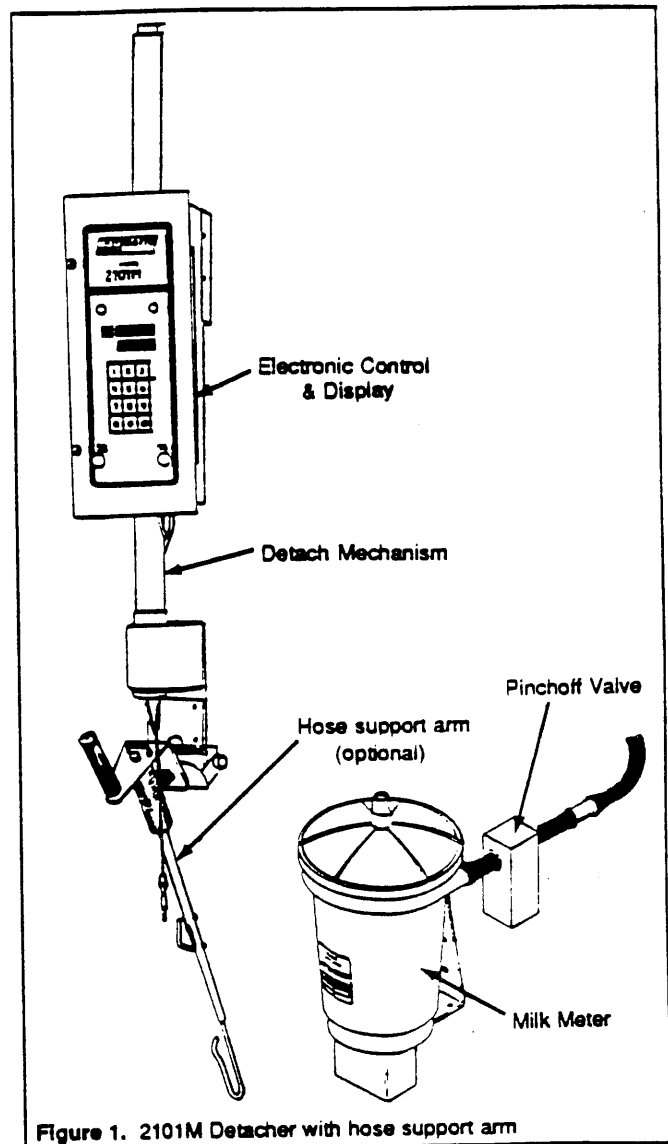

Figure 1. 2101M Detacher with hose support arm

detacher cylinder will automatically retract the link chain and gently detach the milking unit from the cow. The 2101M permits cows to be milked efficiently by providing consistent takeoff of the milking unit.

The 2101M, as shown in Figure 1, consists of five assemblies:

- The Electronic Control and Display
- The Milk Meter
- The Pinchoff Valve
- The Detach Mechanism
- The Hose Support Arm (optional)

A complete explanation of the assemblies' features and functions is given in Section 5, "Detacher System Operation."

The information within this packet is intended to aid both the dealer and the dairyman in the installation and operation of the detacher unit. Read the instructions carefully before assembling and using the equipment to ensure proper installation.

The Table of Contents, which precedes this introduction, lists the sections of this instruction packet in the order in which they should be read and procedures should be carried out.

When installing the detacher unit, the dealer should be equipped with standard installation tools. All non-standard tools will be so indicated in the appropriate sections of this packet.

Special *cautions* and *notes* have been provided throughout this packet to aid the dealer and dairyman in following instructions and making decisions. Read these carefully before installing and using the system.

Proper installation and maintenance of all system parts are essential to obtain maximum benefit from Bou-Matic products.

*The dairyman is responsible for monitoring the detachers to ensure that they are functioning properly.*

## 1. GENERAL INFORMATION

During installation, the dealer will complete sub-sections 1.1 and 1.3.

### 1.1 Unpacking the Detachers

To make sure that you have everything you need to set up a complete system, take all the items out of the packing boxes and check to see that the items correspond to the lists which follow.

A list of 2101M Detacher parts is shown below:

Description	Quantity per Stall
Air Cylinder Assembly & Control Box .....	1
Mounting Brackets (with hardware) .....	2
Milk Meter, Model "M"+ .....	1
Pinchoff Valve .....	1
Hose Support Arm (optional) .....	1

In the unlikely event that something is missing, contact the Bou-Matic Customer Service Department immediately.

A list of dealer supplied electrical system parts is shown below:

Description	Quantity
Δ System Power Supply * .....	as reqd
Power source wiring for circuit breaker box .....	as reqd
Δ Battery Back-up (recommended option) .....	as reqd
1/2" conduit .....	as reqd
12 AWG type TW insulated wire (stranded/solid) .....	as reqd

	Qty per Detacher
Tee Junction Box w/gasketed lid .....	1
Δ 1/2" water-tight strain relief connector .....	1
Δ Setscrew wire connector .....	3

Δ These items are available from Bou-Matic.

\* The number of power supplies required depends on the electrical load that you are connecting. To determine how many will be needed, refer to sub-section 2.1, "Installing the Power Supply."

**Note**  
 If an Agri-comp computer is part of the installation, larger conduit and junction boxes are required to accommodate communication wiring. Refer to the appropriate Agri-comp instruction manual for details.

A list of dealer supplied air system parts is shown below:

Description	Quantity
Air compressor .....	1
Δ Filter-filter-regulator assembly (with gauge) .....	1
1/2" minimum air line .....	as reqd
1/2" ball-type valve .....	2

Other items required in the installation include the following:

Description	Quantity
1/4" concrete anchors or	
Δ 1/4 x 3/4" screw, washer & nut .....	2 per meter
Δ 5/8" milk hose .....	as reqd
Δ Twin air tubing .....	as reqd

### 1.2 Evaluating the AC Power

The AC power for the farm must not be overloaded. If installed in an area with inadequate electrical power, the detacher units may experience poor operation. For this reason, we recommend that a qualified electrician evaluate the load on the farm and barn service entrances to make sure that you are not working with an overloaded system.

### 1.3 Installing Lightning Protection Modules

Lightning protection modules are used to help protect electrical equipment from high voltages caused by lightning strikes. Before installing detachers or other system components, lightning protection modules must be installed on AC power lines, main pole, and power panels serving Bou-Matic automation equipment. For instructions on how to install the modules, refer to literature #9P-476, *Lightning Arrestor Installation Instructions*.

## 2. INSTALLATION

### Note

During installation, all electrical work should be done by a qualified electrician, and all other installation work will be done by the dealer.

### Note

All wiring must be placed inside conduit. AC and DC wiring must not be routed together in the same conduit. If routed together, poor or intermittent detacher operation may occur. In addition, pulsation and DC wiring must not be routed together. Parallel conduits must be located a minimum of 12 inches from each other.

Choose the places where your equipment will be mounted.

### 2.1 Installing the Power Supply

The power supply is used to convert voltages of 120 or 230 volts AC to 11 and 24 volts DC, which is used to power the detachers.

The number of power supplies required for a detacher parlor installation depends on the electrical load that you are connecting. Generally, a 12-unit power supply will supply enough power to operate 12 detachers with or without meters, and a 16-unit power supply will power 14 detachers with meters (16 detachers without meters)—thus the names of the power supplies.

### Note

When installing detacher units in parlors in Canada, use the 12-unit (CSA approved) power supply only.

At this time, mount the necessary power supplies and connect the power source wiring from the AC power panel according to the appropriate literature packet, listed below.

12 Unit Power Supply	Lit. #9P-496
16 Unit Power Supply	Lit. #9P-509

### Note

Do not connect any other electrical equipment to the AC circuit you are connecting between the power panel and the power supply. If connected, that equipment may cause poor or intermittent detacher operation.



Before the power supply can be wired for detacher operations, the conduit and the three 12-gauge wires must be measured and positioned at the appropriate height above the detachers.

To prepare the parlor for power supply and detacher wiring, use the following procedure:

1. Route 1/2" PVC conduit overhead from the power supply to the detachers, assembling the appropriate water-proof junction box at each detacher location. The arrangement of the conduit will vary depending on the parlor setup (see Figure 2).

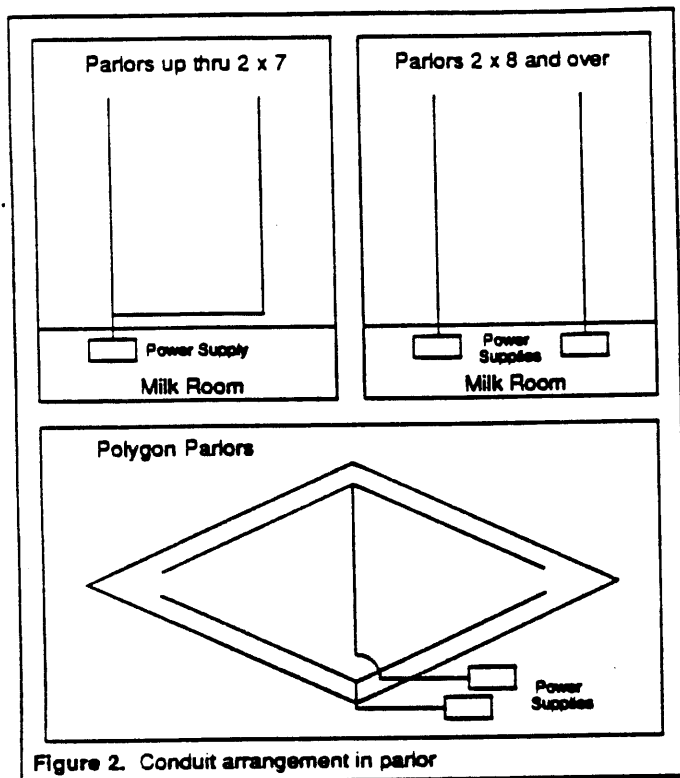

Figure 2. Conduit arrangement in parlor

2. Route the three 12-gauge type TW wires through the entire length of conduit and into the power supply. Leave sufficient wire at the power supply and at each detacher junction box so wire connections can be made.

Once the conduit and wires are in place, the wires can be connected at the power supply. To connect the wires to the power supply, use the following procedure:

1. Strip the wire insulations back .25 inches (6 mm).
2. Connect a wire to the terminal labeled "Common."
3. Connect a wire to the terminal labeled "11 VDC."
4. Connect a wire to the terminal labeled "24 VDC."

Figure 3 shows proper wiring of the DC connector inside each power supply.

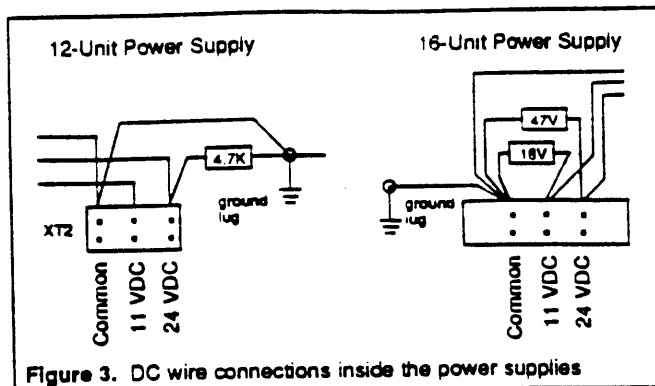

Figure 3. DC wire connections inside the power supplies

If an Agri-comp computer is part of the installation, you should also install the appropriate wires that connect the power supply to the computer at this time. Refer to your Agri-comp Instruction Manual for information on how to connect these wires.

**Note**

We recommend that a battery backup be installed with each power supply to prevent detachers from prematurely detaching, or defaulting to standard address settings if takeoff and flow rate settings are programmed otherwise, during intermittent power fluctuations.

## 2.2 Installing the Air System

The air system consists of an air compressor, a pre-filter, a coalescing filter, a regulator, tubing, valves, and service outlets.

The air compressor is used to supply high-pressure air to the air-operated pinchoff valve at each detacher. The air compressor sizes, listed in the table below, will handle the specified number of detachers plus air-operated feed bowl covers and entrance and exit gates; however, these sizes will not accommodate crowd gates.

Table 1. Recommended Air Compressor Sizes

Number of Detachers	Compressor H.P.	Reserve Tank (Gal)
1-8	1	20
9-18	1	30
19-32	2	60

**Note**

The compressor sizes recommended are based on the use of industrial or heavy-duty compressors only. You should avoid installing lower quality compressors, including almost all fractional horsepower compressors, as they may cause trouble which would lead to additional expenses.

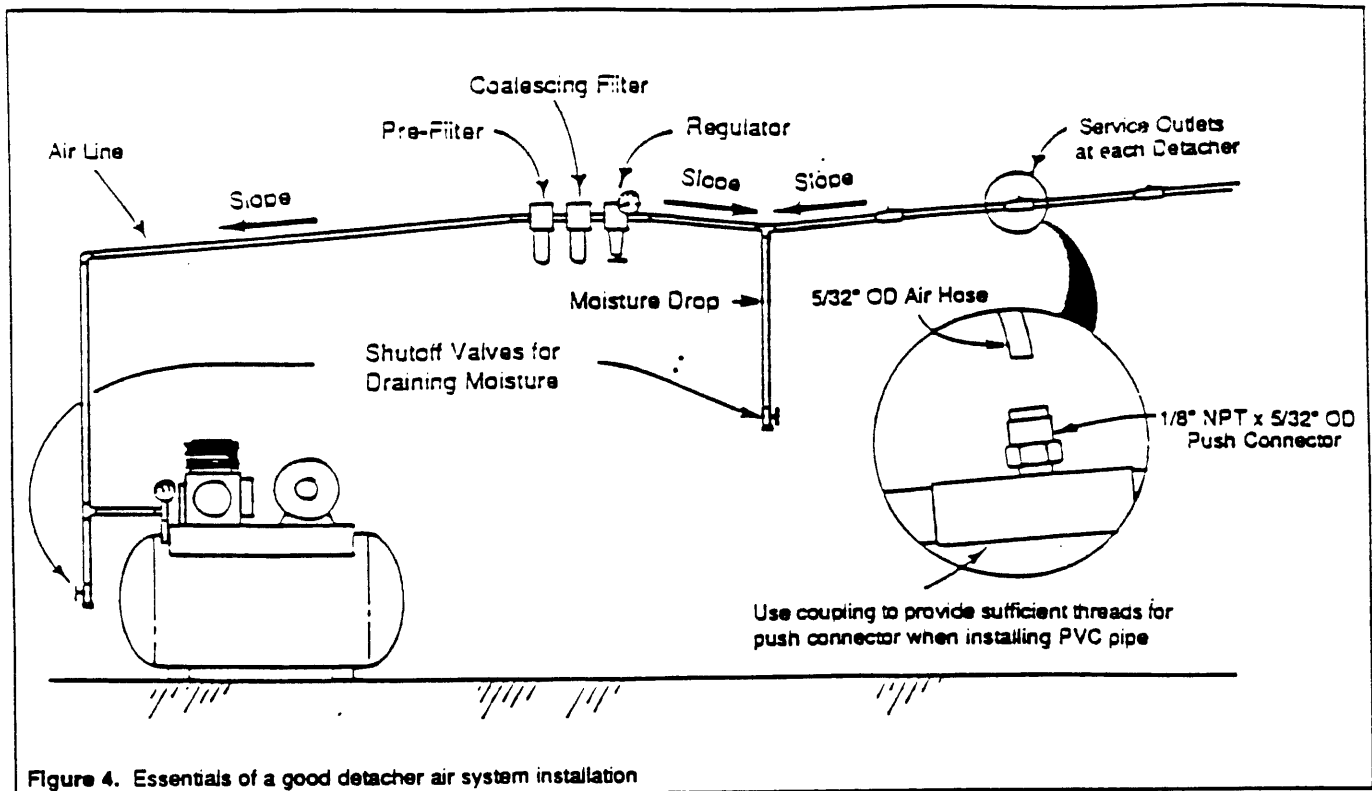

Figure 4. Essentials of a good detacher air system installation

We recommend that you use a coalescing filter on the air system because all valves and cylinders supplied on Bou-Matic detachers are designed for use without oil. Additionally, compressor oil and dirt as well as moisture in the air are the causes of most valve problems. (See the *Dari-Kool/Bou-Matic Equipment Catalog* for information on the filter-filter-regulator.)

When installing the air compressor, choose a dry, convenient place where it will stand. Then, position the air line and assemble the other components of the air system, as shown in Figure 4, using the following procedure:

1. Route 1/2" PVC, copper tubing, or galvanized pipe for the air line from the compressor to where the filter-filter-regulator (F-F-R) will be installed in the parlor. Allow the line to slope upward a minimum of 1 inch per 4 feet of line from the air compressor to the F-F-R.
2. Install the pre-filter, coalescing filter, and regulator assembly (F-F-R), as shown.
3. Set the regulator pressure at 65 to 70 psi.
4. Slope the line downward and away from the regulator.
5. Install a moisture drop in the air line. The moisture drop should be a length of pipe, extending vertically downward, with a drain at its lower end.
6. Slope the line upward and away from the top of the moisture drop for the entire length of detachers. Again, the upward slope must be a minimum of 1 inch per 4 feet of line from the moisture drop to the last detacher.
7. Install a 5/32" push connector in the air line at each detacher. The connectors must point upward. When installing the connectors in the air line, drill and tap an 1/8" NPT hole on top of the line at each detacher location. Installations using PVC pipe require that couplings be installed to provide sufficient threads to secure the connectors.

### 2.3 Installing the Parlor Wash System

Detacher systems using milk meters require clean-in-place (CIP) washing with Bou-Matic Jetter Washers for each detacher. For instructions on how to install the wash system, refer to literature #9P-574, *Parlor Wash System Installation and Operation Instructions*.

### 2.4 Installing the Detachers

To ensure consistent milk measuring, install the detacher/meters on low milk lines only; milk traveling through raised hoses on high milk lines may have a slugging effect which could result in inconsistent measuring.

### 2.4.1 Mounting the Detacher & Hose Support Arm

The detacher hose support arm is factory assembled for right-hand stall installations (the stalls to your right as you face the cow exit gate). When installing the left-hand stalls in a parlor, follow all the steps in the procedure below to mount detachers with arms properly. When installing the right-hand stalls with arms or both sides of the parlor without arms, skip steps 1-5. In any case, use Figures 5, 6, and 7 as guides for assembling detachers to the upper and lower rump rails.

1. Remove the 3/8-24 x 3/4 screw and the lock washer holding the flex arm spring and tube assembly to the arm bracket.
2. Remove the 1/2-13 hex nut, the lock washer, the support arm assembly, and the friction disc from the arm bracket.
3. Move the screw and the 4 spring washers from the right-hand mounting hole in the arm bracket to the left-hand mounting hole. Do not change the assembly order of the spring washers, alternated top to bottom.
4. Reassemble the friction disc and support arm assembly to the arm bracket with the appropriate lock washer and nut.
5. Reassemble the spring and tube assembly to the arm bracket using the 3/8-24 x 3/4 screw and the lock washer.
6. Assemble the bottom mounting bracket and the upper hinge of the flex arm assembly (if used) to the lower rump rail using 2 U-bolts, 4 helical spring lock washers, and 4 hex nuts. The mounting bracket must be assembled between the rump rail and the flex arm assembly, as shown. Then, adjust the mounting bracket and flex arm assembly so that the center of the bracket is 20" to 22" ahead of the outside bend of the rump rail, as shown in Figure 6.
7. Insert the chain guide bushings into the holes provided in the bottom mounting bracket, as shown, and secure them in place using retaining rings.
8. Slide the lower end of the detacher mounting pipe into the bottom mounting bracket until the detacher is properly seated.
9. Assemble the top mounting bracket to the upper end of the mounting pipe using the stainless steel hose clamp. (See Figure 7 for alternate bracket mounting.)

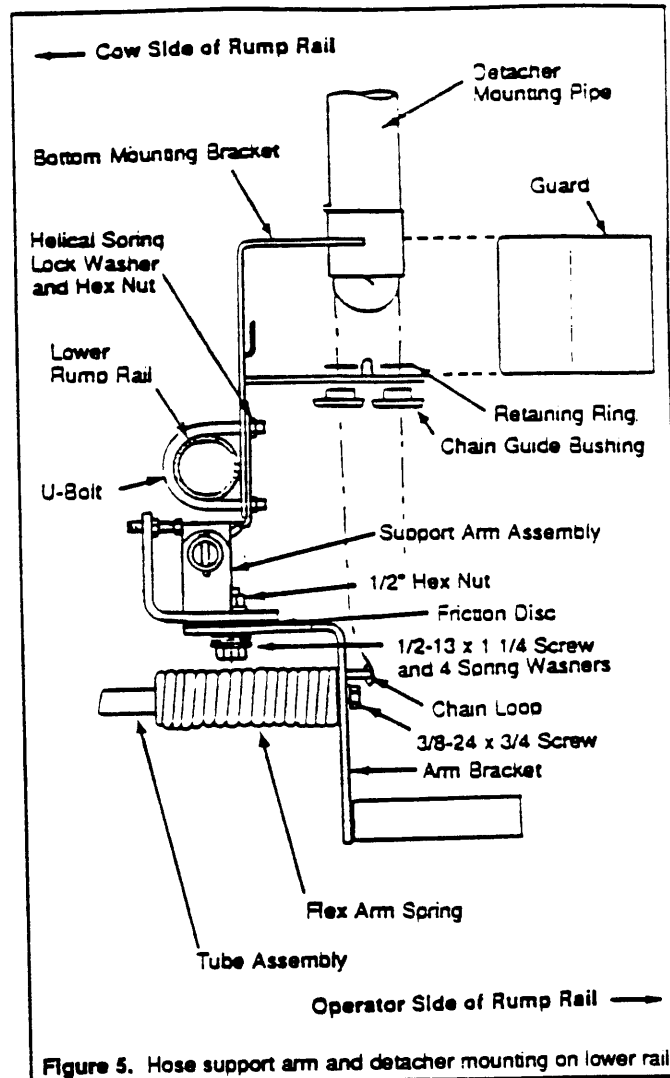

Figure 5. Hose support arm and detacher mounting on lower rail

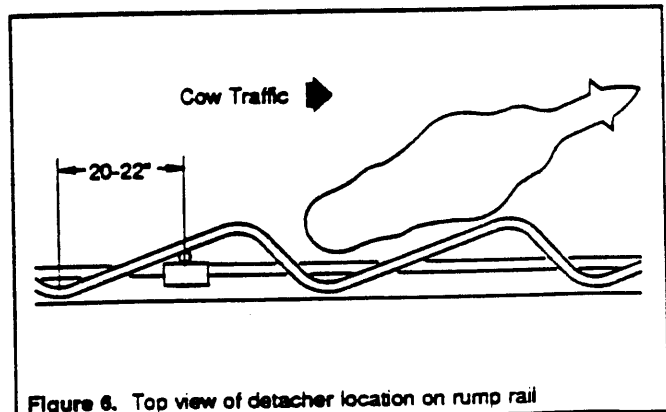

Figure 6. Top view of detacher location on rump rail

10. Assemble the top mounting bracket to the upper rump rail using the remaining U-bolt, 2 helical spring lock washers, and 2 hex nuts. For best appearance, plumb the assembly using a level.
11. Connect one end of the chain to the chain loop on the flex arm assembly using a chain connector link.

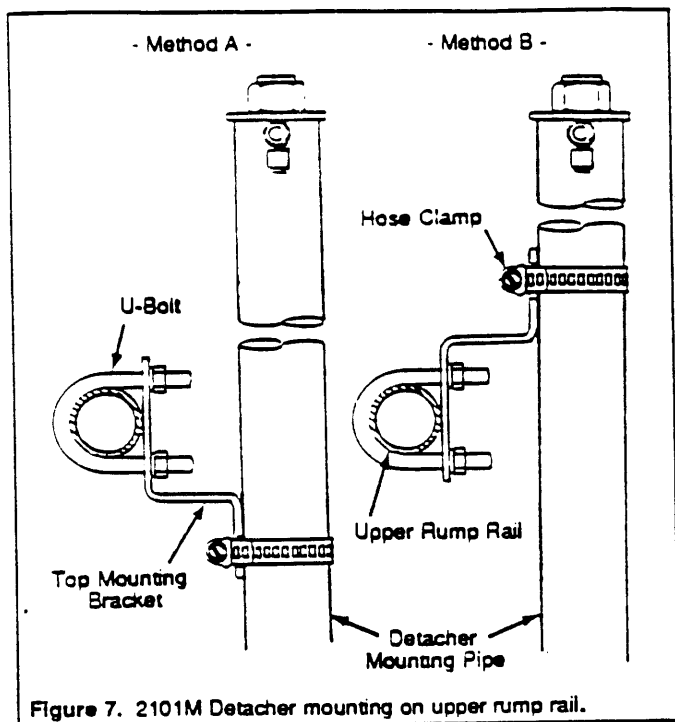

Figure 7. 2101M Detacher mounting on upper rump rail.

12. Thread the chain up through the rear chain guide hole (closest to the rail) in the bottom mounting bracket, through the guard, around the pulley from back to front, down through the guard, and out the front chain guide hole.
13. Conceal the chain by sliding the guard into position on the bottom mounting bracket.

Mechanical adjustments must be made once the entire system is connected. (See sub-section 2.4.6.)

### 2.4.2 Mounting the Milk Meter

Mount the milk meter to a concrete or steel curb, as shown in Figures 8 and 9, using the following procedure:

1. Mount the milk meter bracket to the concrete curb using three 1/4" concrete anchors. Ensure that the horizontal plane of the bracket is level.

or...

Mount the curb meter bracket to the steel curb using two 1/4-20 x 3/4 bolts, 2 plain washers, 2 lock washers, and 2 nuts.

Ensure that the vertical sides of the bracket are plumb using a level.

Then, mount the milk meter bracket to the curb meter bracket using an acute-angle support bracket, three 1/4-20 x 3/4 bolts, 6 plain washers, 3 lock washers, and 3 nuts.

Assemble the support bracket to the right side of the curb meter bracket as viewed from the front of the meter.

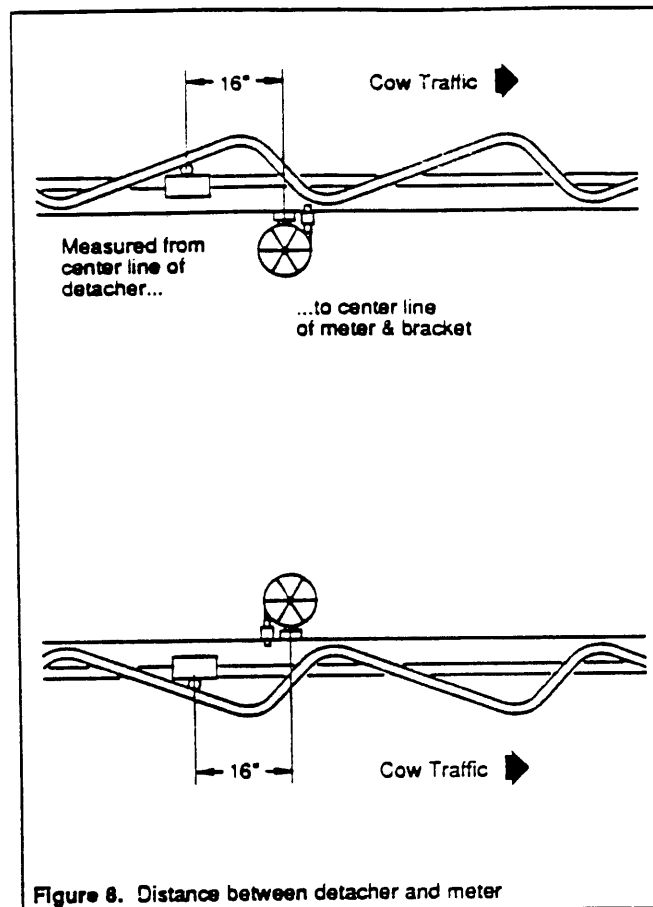

Figure 8. Distance between detacher and meter

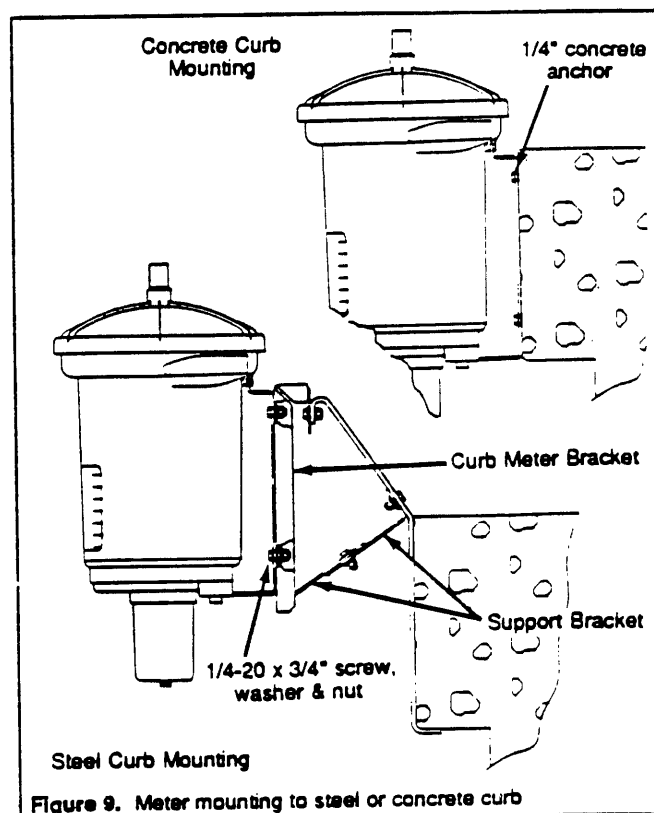

Figure 9. Meter mounting to steel or concrete curb

Secure the brackets to the steel curb using the right-angle support bracket, two 1/4-20 x 3/4 bolts, 3 plain washers, 2 lock washers and 2 nuts. Ensure that the vertical front and the horizontal flange of the milk meter bracket are level.

The meter may be disassembled from the meter bracket to ease bracket mounting to the curb. Once the brackets have been mounted, reassemble the meter to the meter bracket.

When the meter and brackets are properly mounted and level, tighten all mounting hardware.

6. Remove the lock nut from the strain relief connector on the loose end of the milk meter cable.
7. Route the milk meter cable through the hole in the bottom of the detacher, and slide the lock nut back onto the cable.
8. Connect the milk meter cable to the unused connector on the electronic control inside the detacher.
9. Finally, secure the lock nut back onto the strain relief connector.

#### 2.4.3 Connecting the Hoses

Once the detachers and meters have been mounted and the claws have been assembled, hoses can be connected to the milking system using the following procedure:

1. Connect one end of a 5/8" milk hose to the thumb nipple on the claw. The hose (approximately 54" long) should be routed through a loop in the hose support arm, if used.
2. Insert a stainless steel nipple into the loose end of the milk hose.
3. Connect a 5/8" black, rubber hose (approx 6" long) to the milk inlet on the milk meter, and position the pinchoff valve at the center of the hose.

#### Note

Clear PVC milk hose should not be routed through the pinchoff valve because it is too rigid to be pinched by the valve during the retract cycle.

4. Connect the rubber hose to the nipple in the milk hose.
5. Connect one end of a 5/8" milk hose to the milk outlet on the milk meter—the other end to the milk line. Slope the hose so as not to create a milk trap.
6. Connect one end of the twin vacuum tube to the air fork on the claw—the other end to the pulsator.
7. Connect the 5/32" black air hose from the detacher to the pinchoff valve's push elbow connector by pushing the hose (seating it firmly) into the connector.
- 8

#### 2.4.4 Connecting Power to the Detachers

Connect power to the detachers and verify proper voltages using the following procedure:

1. Extend the power cord from each detacher up to its water-proof junction box.
2. Connect the wires in each power cord to their corresponding wires from the power supply. Connections must be made using setscrew-type wire nuts, as shown in Figure 10. Secure the cord to the junction box with a 1/2" water-tight, strain-relief connector.

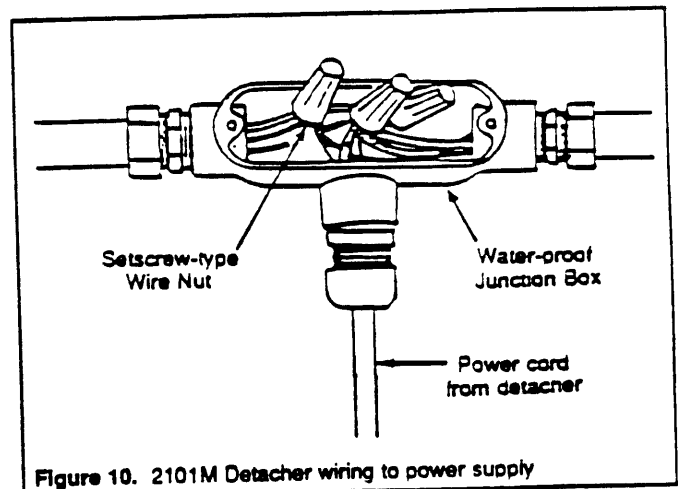

Figure 10. 2101M Detacher wiring to power supply

3. Using a voltmeter, verify that the voltages at the power cord agree with those listed in Table 2.

Table 2. Voltages at the Power Supply

Place Measured	Voltage
Green (-) to white (+)	11VDC
Green (-) to black (+)	24VDC

If the voltages do not agree (to within  $\pm 10\%$ , meaning green to white is 10 to 12 VDC and green to black is 21 to 27 VDC), action must be taken at once to correct them.

#### 2.4.5 Connecting Air to the Detachers

Before connecting the air supply lines to the detachers, blow air through the lines to remove any foreign matter from drilling, etc. Then, connect the yellow air hose of each detacher to the service outlet directly above the detacher on the air supply line by pushing the hose (seating it firmly) into the connector.

## 2.4.6 Making Mechanical Adjustments

Once the detachers have been installed and power and air have been connected to them, you should make certain mechanical adjustments, as necessary.

### 2.4.6.1 Adjusting the Link Chain

To adjust the link chain for proper detachment of the milking unit, use the following procedure:

1. Press the **ATTACH/DETACH** button to retract the cylinder.
2. Position the flex arm back so it is vertical.
3. Clip the cold shut connector approximately 8" from the end of the chain that extends downward through the front chain guide hole.  
The connector acts as a stop to hold the arm vertical when the cylinder is fully retracted. (See Figure 11.)

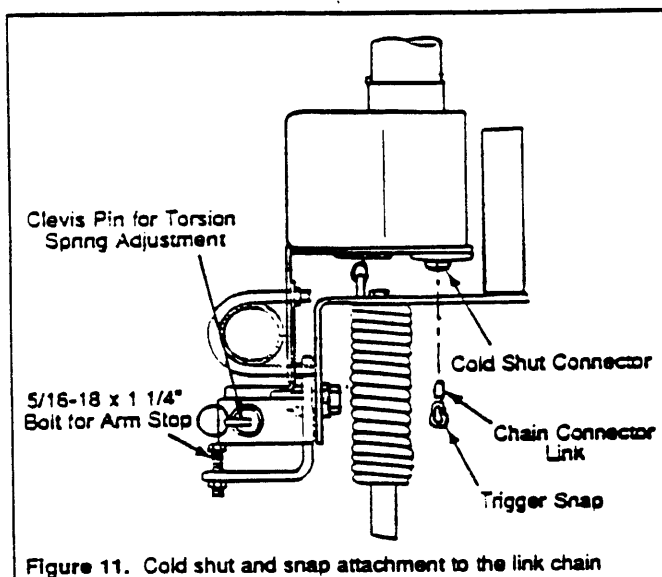

Figure 11. Cold shut and snap attachment to the link chain

4. Attach a trigger snap onto, or near, the end of the chain using a chain connector link.  
The snap should be positioned such that when it is clipped to the claw assembly, the teat cups will clear the curb and gutter when the chain is retracted. Also, make sure that the claw assembly hangs at a comfortable position for the operator. Then, cut off any excess chain that extends beyond the snap.

### 2.4.6.2 Adjusting the Arm Stop Mechanism

The arm stop prevents the flex arm from hitting a cow's belly when the milk and vacuum hoses are not hooked onto the flex arm hook.

To adjust the stop so that when the flex arm is activated the flex arm will clear the cow, loosen or tighten the 5/16-18 x 1 1/4" bolt, and use the hex nut to lock it in position.

### 2.4.6.3 Adjusting the Torsion Spring

The torsion spring has been factory adjusted to move the flex arm automatically out and underneath a cow when the milking unit is to be attached. The factory adjustment is correct for average installations, but should you need to make further adjustments, use the following procedure:

1. Hold the head of the flex arm shaft stationary with a wrench.
2. Remove the clevis pin from the adjusting ring.
3. Turn the shaft to the desired position using the wrench. Turning the shaft clockwise loosens the torsion spring; turning it counterclockwise tightens the spring.

#### Caution

The shaft should not be tightened past five holes in the adjusting ring (a total rotation of 300°). If the shaft is turned past the fifth hole, undue stress would be put on the spring, which could cause the spring to break or the arm stop to bend.

4. Place the clevis pin back into the adjusting ring and release the wrench.

### 2.4.6.4 Adjusting the Hose Support Arm

Adjust the swivel action of the hose support arm, as necessary, by tightening or loosening the fastener which holds the flex arm assembly to the bottom mounting bracket. When properly adjusted, the flex arm should be permitted to swivel (with some tension) using the arm handle.

An adjustment can also be made to shorten or lengthen the flex arm if desired, using the following procedure:

1. Remove the two #8-32 hex nuts, #8 internal tooth washers and 8-32 x 7/8 round head machine screws from the hook end of the flex arm.
2. Determine the desired hook length, making sure that the arm will not hit the floor or any other obstacle.
3. Drill two 3/16" diameter holes through the inner tube using the existing outer tube holes as a guide.
4. Reassemble the screws, washers, and nuts, tightening them as necessary.

### 2.4.6.5 Adjusting the Takeoff Speed

Adjust the takeoff (retract) speed of the detach mechanism by loosening the lock ring on the flow control valve at the top of the air cylinder, then loosening the thumbscrew to make the chain retract faster or tightening the screw to slow down the retract speed. Once adjusted, retighten the lock ring.

### 2.4.6.6 Changing Detacher Address Settings

Individual addresses must be assigned and changed inside detachers when an Agri-comp computer is part of the installation, so that the computer can identify which detacher is communicating to it and can respond by sending milking data to that detacher's display. Installations not using an Agri-comp computer do not require that any addresses be set inside detachers so no address change is necessary.

To assign and change address settings inside detachers, refer to the appropriate Agri-comp computer instruction manual.

### 2.4.6.7 Changing the Takeoff and Flow Rate Settings

The takeoff delay is a feature which allows a cow to resume her milk flow, if it should momentarily pause, before the milking unit detaches. The delay time is the period of time between when the milk meter measures less than the predetermined milk flow rate and the milking unit detaches. The 2101M is factory set with a 13-second takeoff delay and a milk flow rate of 0.7 pounds per minute. Generally, the detachers should all be operated using their same standard factory settings, however, you may want to adjust the takeoff and flow rate settings in certain situations.

The detacher takeoff delay can be set to various delay times: 8, 13, or 22 seconds. These delay times can be set with a switch inside the electronic control, from the detacher keypad, or from the Agri-comp computer. The flow rate can be changed from the detacher keypad or from the Agri-comp computer.

#### Switch Settable Takeoff Delays

Each detacher control is equipped with a 10-position address switch, as shown in Figure 12, which can be set to any of the delay times mentioned above, using positions 8 and 9.

To check the current delay setting on a detacher, enter the command 2 # at the detacher's keypad. The display will show the flow rate and takeoff delay time.

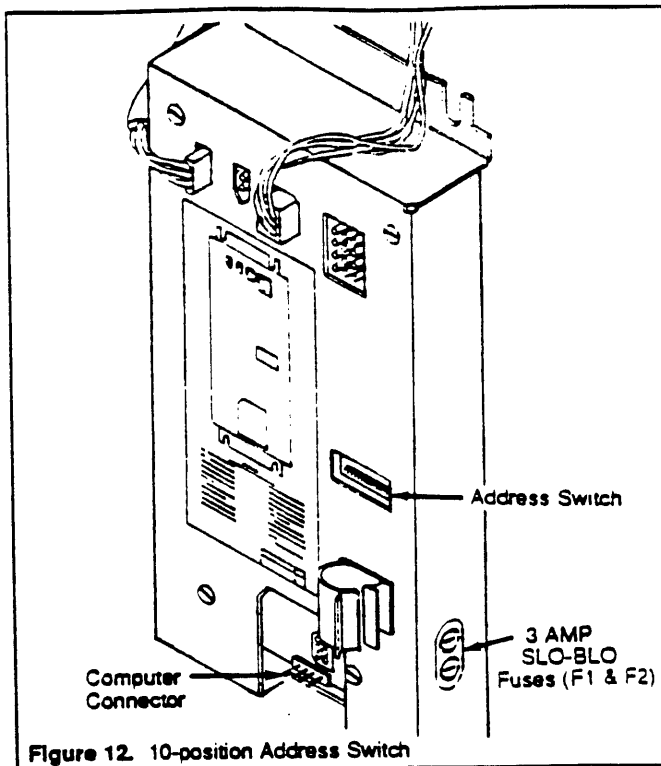
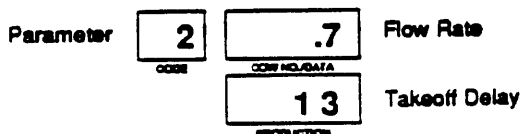

Figure 12. 10-position Address Switch

Enter the command 1 # to return to the time and production display.

To change the delay time on a detacher, choose one of the settings listed in Table 3, and set switch positions 8 and 9 accordingly.

Table 3. Switch Settings for Takeoff and Flow Rate Delays

Takeoff (seconds)	Position 8	Position 9	Flow Rate (lbs/min)	Flow Rate (liter/min)
22	OFF	ON	0.7	0.3
*13	ON	OFF	0.7	0.3
8	ON	ON	0.7	0.3

\* Factory setting for parlor units.

Note: Flow rate settings are to be entered in tenths of a pound per minute.

**Temporary Flow Rate and Takeoff Delay—Individual Detachers**  
Generally, the detachers should all be operated using the same standard factory settings; however, you may want to adjust the takeoff setting for an individual cow, especially a fast-milking one. In such a case, you can reprogram both the flow rate and the takeoff delay at the detacher keypad. (Keypad entered delays and flow rates temporarily override preset switch settings.)

When entering values for the flow rate and takeoff delay, keep in mind that the flow rate is entered in tenths of pounds and the takeoff delay is entered in seconds.

To temporarily change both the flow rate and takeoff delay for a milking, use the following procedure:

1. Set the milking mode to automatic (if not already set). Refer to sub-section 5.2, "Understanding the Automatic & Manual Modes," for information on selecting modes.
2. Attach the milking unit to the cow whose flow rate and takeoff delay times you want changed.
3. Enter the following command at the keypad, specifying what flow rate and takeoff delay time you want assigned:

2 \* [flow rate] \* [takeoff delay] #

The switch programmed flow rate and takeoff settings will be overridden, and the detacher will continue milking with the new flow rate and takeoff delay time entered until the cow is milked out and the milking unit is attached to the next cow. For example, to change the flow rate from 0.7 lbs/min to 0.8 lbs/min and the takeoff delay time from 13 seconds to 5 seconds, you would enter the command:

2 \* 8 \* 5 #

The display would respond with:

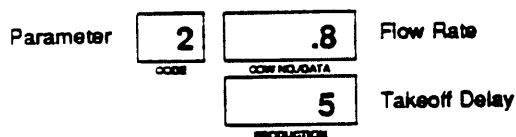

4. Change the display back to time and production with the command:

1 #

**Note**

The new settings will be valid only for the currently milking cow, and the detacher will automatically return to its switch programmed settings upon attach to the next cow.

We recommend that you install battery backups whenever detachers are used this way. Battery backups minimize intermittent power fluctuations which can cause detacher memory loss. If power is lost, battery backups will supply power to detachers and meters for up to one minute.

The milking unit will automatically detach approximately 22 seconds after the claw empties.

**Permanent Flow Rate—Entire Parlor**

Although we do not recommend it, in rare cases, a dairyman may want the entire parlor to have takeoff and flow rate settings other than the 0.7 lbs/min and 13 seconds programmed into the electronics. For such cases, switch positions 8 and 9 must both be switched off. Switching them off permits you to program the units from the detacher keypad, as explained earlier in this section under "Temporary Flow Rate and Takeoff Delay." Unlike the temporary settings, which automatically allow a detacher to revert back to its switch settings, however, these permanently programmed parlor settings will remain in the detachers' memories for all subsequent milkings, and they will apply for all cows milked until the detachers are manually reprogrammed, the system experiences power failure, or the detachers are reset. *Note:* Following a power loss, if switch positions 8 and 9 are both set to OFF, the flow rate and takeoff settings will return to the standard 0.7 lbs/min and 13 seconds. If you are unaware of the power loss, you may not realize that the settings have changed unless you regularly check them at the display or computer. For this reason, we do not recommend that this option of permanent takeoff and flow rate be used.

If you do decide to use this option, keep in mind that all detachers should be operated with positions 8 and 9 off. When an Agri-comp computer is part of the installation, you may set switch positions 8 and 9 off, but the takeoff delay and flow rate settings must be made at the computer rather than the detachers (refer to your Agri-comp computer instructions), as computer settings will override the detacher in this case. When a faster than normal takeoff setting is desired, the fastest reliable setting is 0.9 lbs/min and 5 seconds.

To reenter takeoff settings after power has been turned off, manually reset the detachers by pressing the AUTO/MANUAL and ATTACH/DETACH buttons at the same time, releasing the AUTO/MANUAL button first. Then, enter values as explained above.

**2.4.6.8 Changing the Dump Delay Setting**

The dump delay is the period of time between when the milking unit detaches and the milk meter empties the remaining 3.5 lbs of a cow's milk production. The 2101M is factory set with a 30-second dump delay, and it should normally be operated using this standard factory setting; however, you also have the option of setting the delay to zero.

To change the delay time on a detacher, choose one of the settings listed in Table 4, and set the address switch position 7 accordingly.

**Table 4. Switch Settings for Dump Delay**

Dump Delay (sec)	Position 7
30	ON
0	OFF



Operating the detachers with the 30-second dump delay allows the operator ample time to reattach the milking unit in the event that a cow experiences an early detach. On the other hand, operating them with the 0-second dump delay would not allow the operator any time to reattach. Providing time for reattachment is especially important when you are using an Agri-comp computer, because the releasing of milk signals the computer to close the cow's production record. As a result, if a detacher with a dump delay of zero seconds were to detach early, upon reattachment to the cow the computer would not reopen the cow's record—the additional milk production would simply not be counted for that cow.

### 2.4.6.9 Changing the Unit of Measure

The milk meter can measure milk in pounds or kilograms, depending on the setting of switch position 10. To change the unit of measure on a detacher, choose one of the settings listed in Table 5, and set switch position 10 accordingly.

**Table 5. Switch Settings for Unit of Measure**

Units of Measure	Position 10
Kilograms	ON
Pounds	OFF

**Note:** When setting the unit of measure to kilograms, do not convert takeoff settings to kilograms. All takeoff settings must be in pounds.

### 2.4.7 Checking Detacher Functions

Proper operations must be verified at the detachers before they can be used. If an Agri-comp computer is part of the system, disconnect communications between the computer and the detachers by switching off the DATA COLLECT switch on the front of the computer. Then, step through each of the action items listed in Table 6 for each detacher, ensuring the proper results. (This procedure assumes that standard factory settings have not been altered.) If you are unable to obtain the expected response after checking and correcting the probable cause(s), refer to Section 4, "Parts Replacement," for instructions on replacing the Detacher circuit board.

**Table 6. Dealer's System Checkout Guide**

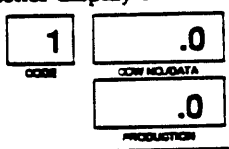
Action	Expected Response	If response differs, then
Turn the vacuum and power supply on. Unplug the detacher power cord (the link chain should extend). Then, plug it in again.	The detacher display should read: 	<ol style="list-style-type: none"> <li>1. Verify that the voltage to the detacher is 11VDC (<math>\pm 10\%</math>).</li> <li>2. Check the 11V fuse on the electronic control assembly.</li> </ol>
	The air cylinder should retract, and the pinchoff valve should close.	<ol style="list-style-type: none"> <li>1. Verify that the voltage to the detacher and solenoid valve is 24 VDC (<math>\pm 10\%</math>).</li> <li>2. Check for pinched air hoses.</li> <li>3. Check the flow control valve at the top of the air cylinder to see that the thumbscrew is not screwed in too tight.</li> <li>4. Check the air cylinder to see that the rod is not bound up.</li> <li>5. Check the solenoid valve for plugged ports by separately disconnecting the air lines and cycling the valve. If plugged, replace the valve.</li> </ol>
	The NO MILK lamp should turn on.	<ol style="list-style-type: none"> <li>1. Check the lamps and wiring to them with a test module.</li> <li>2. Check the switch buttons by loosening the two lower nuts on the electronic control, then pushing the switches with your fingers.</li> </ol> <p><i>Continued on next page</i></p>

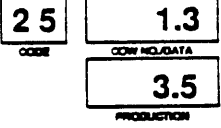
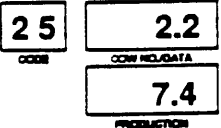
Action	Expected Response	If response differs, then
<p>Manually reset the detacher by pressing the AUTO/MANUAL and ATTACH/DETACH buttons at the same time, releasing the AUTO/MANUAL button first.</p>	<p>The NO MILK lamp should remain on and the display should read:</p> <div style="text-align: center;">  </div> <p>The COW NO./DATA window should begin incrementing "Time."</p>	<p>* Follow the instructions above where the expected response is "The NO MILK lamp should turn on."</p>
<p>Press the AUTO/MANUAL button.</p>	<p>The MANUAL lamp should turn on, and the COW NO./DATA window should continue incrementing "Time."</p>	<p>* Follow the instructions above where the expected response is "The NO MILK lamp should turn on."</p>
<p>Press the ATTACH/DETACH button (to simulate detaching the unit).</p>	<p>The lamps should remain on, the air cylinder should retract, and the display should read:</p> <div style="text-align: center;">  </div> <p>(The value shown in the COW NO./DATA window may vary.)</p> <p>Thirty seconds after detach, the meter motor should turn for approx. 30 seconds (simulating dumping). Then, the MANUAL lamp should turn off.</p>	<p>* Follow the instructions above where the expected response is "The NO MILK lamp should turn on."</p>
<p>Remove the meter cover and rotor. Then, press the ATTACH/DETACH button (to simulate attaching the unit to a cow).</p>	<p>The detacher should respond as explained above where the action is to manually reset the detacher.</p>	<p>* Follow the instructions above where the expected response is "The NO MILK lamp should turn on."</p>
<p>Twelve seconds after pressing the button, lift the meter float (to simulate a steady milk flow).</p>	<p>The NO MILK lamp should turn off, and the PRODUCTION window should begin incrementing.</p>	
<p>Release the meter float before 3 minutes elapses.</p>	<p>The PRODUCTION window should stop incrementing, and, after the end-of-milk delay, the NO MILK lamp should light constantly. After 2.2 minutes, the "Time" should stop incrementing, the air cylinder should retract, the NO MILK lamp should flash (simulating early detach), and the display should read:</p> <div style="text-align: center;">  </div> <p>(The value shown in the PRODUCTION window may vary.)</p> <p>Thirty seconds after detach, the meter motor should turn for approx. 30 seconds (simulating dumping). The NO MILK lamp should continue flashing.</p>	

Continued on next page

Checkout guidelines continued

Action	Expected Response	If response differs, then
Reassemble the rotor and meter cover. Then, press 2 # at the keypad to check the detacher's takeoff delay setting.	The detacher display should read: <div style="display: flex; justify-content: space-around; align-items: center;"> <div style="border: 1px solid black; padding: 2px; text-align: center;">2 <small>CODE</small></div> <div style="border: 1px solid black; padding: 2px; text-align: center;">.7 <small>COV HOLD DATA</small></div> </div> <div style="margin-top: 5px; text-align: center;"> <div style="border: 1px solid black; padding: 2px; text-align: center;">13 <small>PRODUCTION</small></div> </div>	Review sub-section 2.4.6.7, "Changing the Takeoff and Flow Rate Settings," and adjust the takeoff accordingly.
Press the ATTACH/DETACH button once (to attach) then a second time to check shutoff (detach) operation.	Vacuum to the claw should shut off just before the air cylinder retracts and detaches the unit.	
Water test each meter for accuracy according to the <i>Milk Meter Accuracy Test Instructions</i> , literature #9P-341.	Noted in literature #9P-341.	Ensure that the meter is level. Then, perform the test again.
At the display, press: 1 2 * 3 4 5 6 * 7 8 9 0	The detacher display should read: <div style="display: flex; justify-content: space-around; align-items: center;"> <div style="border: 1px solid black; padding: 2px; text-align: center;">1 2 <small>CODE</small></div> <div style="border: 1px solid black; padding: 2px; text-align: center;">3 4 5 6 <small>COV HOLD DATA</small></div> </div> <div style="margin-top: 5px; text-align: center;"> <div style="border: 1px solid black; padding: 2px; text-align: center;">7 8 9 0 <small>PRODUCTION</small></div> </div>	Check the keypad cable connections. If no results, replace the keypad.  To clear the display, press # #
At the display, press: 8 8 * 8 8 8 8 * 8 8 8 8	The detacher display should read: <div style="display: flex; justify-content: space-around; align-items: center;"> <div style="border: 1px solid black; padding: 2px; text-align: center;">8 8 <small>CODE</small></div> <div style="border: 1px solid black; padding: 2px; text-align: center;">8 8 8 8 <small>COV HOLD DATA</small></div> </div> <div style="margin-top: 5px; text-align: center;"> <div style="border: 1px solid black; padding: 2px; text-align: center;">8 8 8 8 <small>PRODUCTION</small></div> </div>	Check the Detacher Display circuit board connections. If no results, replace the Detacher circuit board.  To clear the display, press # #

### 3. TROUBLESHOOTING

Table 7 provides helpful suggestions on troubleshooting some problems that the dairyman might experience with the 2101M Detacher or other system components. Troubleshooting should be done only by an authorized Bou-Matic dealer or technician.

**Table 7. Troubleshooting Guide**

Symptom	Possible Cause	Action
The lamps and/or display will not light at the detacher.	The detacher and/or power supply are not getting power.	<ol style="list-style-type: none"> <li>1. Verify that the voltages to the detacher are 11 and 24 VDC (<math>\pm 10\%</math>).</li> <li>2. Check the breakers or fuses in the AC power panel. Correct the problem and check for shorted components in the power supply and detacher.</li> <li>3. Check fuses F1 and F2 in the detacher. If blown, replace the fuse(s) and check for shorted components in the power supply and detacher.</li> <li>4. Check for loose or stranded power cable connections.</li> </ol>
<p><i>Continued on next page</i></p>		<p>The Detacher circuit board is defective. Replace the circuit board.</p>

Troubleshooting guidelines continued

Symptom	Possible Cause	Action
The lamps and/or display will not light at the detacher.	The lamp bulb(s) are burned out.	Replace the bulb(s).
The detacher will not retract.	The detacher is not getting power.	Verify that the voltages to the detacher are 11 and 24 VDC ( $\pm 10\%$ ).
	The solenoid valve is not getting power.	Verify that the voltage to the solenoid is 24 VDC. If the measurement differs, check cable connections and Detacher circuit board using a test module.
	The detacher is not getting sufficient air pressure.	Check the air supply system; the air pressure should be 65 to 70 psi.
The detacher detaches the milking unit too soon.	The milk meter is not properly measuring the milk flow rate.	1. Check for mineral and protein buildup on the float tube; clean if necessary. 2. Check the motor for proper operation. 3. Check the rubber on the rotor; if torn grooved, or separated, replace rotor.
	The takeoff delay is incorrectly set.	Check the setting at the detacher (2 #).
	The meter contains an excessive amount of foam, preventing the float from rising properly.	Check the vent in the Visi-Nipples. If enlarged (more than .020" diameter), replace the Visi-Nipple.
The detacher stays on too long.	The detacher is in manual mode, but the MANUAL lamp is not lit.	Press the AUTO/MANUAL button for automatic operation & check the bulb.
	The takeoff delay is incorrectly set.	Check the setting at the detacher (2 #).
	The float is stuck.	Check for mineral and protein buildup or foreign material between the float and float tube; clean float, if necessary, according to the washing procedure.
The detacher will not attach.	The control button is not making contact with the switch on the Detacher board.	Adjust the circuit board up or down so that the switch makes contact.
	The electronics have malfunctioned.	Manually reset the detacher as explained in Table 6, "System Checkout Guide."
	The keypad is shorted.	At the detacher keypad, press: 1 2 * 3 4 5 6 * 7 8 9 0.  If the keypad malfunctions, replace it.

Continued on next page

Troubleshooting guidelines continued

Symptom	Possible Cause	Action
While milking in the manual mode, the detacher will not detach when the ATTACH/DETACH button is pressed.	The control button is not making contact with the switch on the Detacher circuit board.	Adjust the circuit board up or down so that the switch makes contact.
	The solenoid valve or the electronics are not working.	Check the air system and detacher unit shutoffs.
Vacuum to the claw is not shutting off.	The pinchoff valve is not getting sufficient air pressure.	Check the air line for a pinched or plugged line.
	The hose routed through the pinchoff valve is stiff and dry from aging.	Check the hose. If it is not soft enough to collapse, replace it.
The display shows incorrect or unusual characters.	The electronics have malfunctioned.	Manually reset the detacher as explained in Table 6, "System Checkout Guide." Then, enter 88*8888*8888 at the keypad. If the display is still incorrect, replace the Detacher circuit board.
The detacher displays exceptionally high or low production or does not increment production at all.	The meter is not level.	Ensure that the meter is level. Then, perform the <i>Milk Meter Accuracy Test</i> literature #9P-341.
	The rotor gasket is torn or grooved.	Replace the rotor.
	The reed switch is open, causing the float to stick.	Using a voltmeter or test module, check the reed switch. If the switch does not close when the float is lifted, check the position of the switch in the tube. If no improvement, replace the switch.
	The meter motor is not turning, causing an early detach.	Verify that voltage to the motor is 11 to 14 VDC. If voltage is correct, check the motor and gear box. If no power, then check fuse F2, cable, and reed switch.
	The magnetic sensor/shutter assembly is not functioning (counting) properly, causing an early detach.	Using a test module, check the cable for loose or broken leads. If the cable is OK, then replace the sensor assembly or the motor gear box assembly.
The display dims and stays dim. If you are using an Agri-comp computer...	The DATA COLLECT switch at the Agri-comp computer is off, the communications cable is pinched or broken, or the computer has failed.	Check to see that the DATA COLLECT switch is on at the Agri-comp computer. If it is, the computer may have failed.
If you are not using an Agri-comp computer...	The optional 4-position terminal block is missing from the computer connector on the Detacher circuit board.	Check to see that the terminal block is in place and pins 2 and 4 are jumpered together for the optional computer connector.

Continued on next page

Troubleshooting guidelines continued

Symptom	Possible Cause	Action
The meter will not empty after detach.	The meter motor is not turning.	Manually reset the detacher as explained in Table 6, "System Checkout Guide." Then, raise the float inside the meter to turn the rotor. If the rotor does not turn, check the meter cable connections using a test module. If the connections are OK, replace the reed switch assembly. Check for bad motor using test module.
	The Detacher circuit board is defective.	Manually reset the detacher as explained in Table 6, "System Checkout Guide." Then, check the cable for loose or broken leads using a test module. If the cable is OK, replace the Detacher circuit board.
	The vent hole in the cover is plugged.	Clean the meter cover's vent hole.
	Vacuum from the wash line to the top of the meter is not shutting off.	Check the air system and detacher unit shutoffs.
The voltage at the power supply does not read 11 and/or 24 VDC.	The power supply is not getting power.	<ol style="list-style-type: none"> <li>1. Verify that the voltages to the detacher are 11 and 24 VDC (<math>\pm 10\%</math>).</li> <li>2. Check the breakers/fuses in the AC power panel. Correct the problem and check for shorted components in the power supply and detacher.</li> <li>3. Check for loose or stranded power cable connections.</li> </ol>
	The power supply transformer is not getting power.	Check the fuse and transient protector in the power supply. Check for a possible open switch.
	The transformer is open.	Check for 11 and 24 VDC with wires disconnected from the rectifier. If one or both voltages are not present, replace the transformer.
	The rectifiers are open.	Verify that there is continuity from top lead to (+) and no continuity from top lead to (-). Then, reverse the meter leads and try again. The results should be opposite. If not, replace the rectifier.
	The output voltage protectors are shorted.	Disconnect one end of voltage protector and check with voltmeter. If continuity is indicated, replace protector. (Voltage protectors will indicate an open circuit if good.)

Continued on next page

*Troubleshooting guidelines continued*

Symptom	Possible Cause	Action
The voltage at the power supply does not read 11 and/or 24 VDC.	The capacitor is shorted.	Check capacitor with voltmeter at a setting of R x 1000 or higher. The needle should go up the scale and fall back down if the capacitor is good. If the needle goes up but stays or does not move at all, then the capacitor is bad and should be replaced.
The detacher will not communicate with the Agri-comp computer.	Pins 2 and 4 are jumpered together for detachers without Agri-comp computer.	Remove jumper between pins 2 and 4.
	The electronics have malfunctioned.	Unplug all connectors at the detacher electronics, according to the order specified on the electronics label. (Remove terminal block for easier troubleshooting.) Then, reattach connectors in order one at a time, checking for communications each time until the malfunction is found.
	The communications cable is shorted or open.	Check for poor connections or a cable that is worn through.

## 4. PARTS REPLACEMENT

This section covers the replacement of some of the simpler detacher/meter parts and assemblies. Instructions for more complicated parts and assemblies are included in the repair kits for those parts.

### Replacing the Detacher Circuit Board

Use the System Checkout Guide (Table 6) and Troubleshooting Guide (Table 7) to determine whether the electronics inside a detacher are defective. If they are found to be defective, replace the Detacher circuit board, inside the electronic control.

To replace the Detacher circuit board, use the following procedure:

1. Open the cover of the detacher.
2. Disconnect the cables from the electronics assembly according to the order specified on the electronics label, pulling on their connectors—not the wires.
3. Remove the two, top mounting nuts that secure the electronics to the cover, and loosen the bottom two.
4. Lift the electronics assembly up and out of the enclosure.
5. Set the switches on the new electronics assembly identical to the switch settings on the defective one.
6. Position the new electronics on the back of the cover the same way that the defective one was positioned.
7. Reassemble the top mounting nuts, and tighten all four nuts to secure the electronics in place.
8. Then, reconnect all cables according to the order specified on the electronics label.

#### Caution

Failure to disconnect and reconnect cables as specified on the electronics label may result in damaged electronics.

Run through each of the steps in the System Checkout Guide a second time to ensure that the new Detacher circuit board functions properly.

### Replacing the Spade Drive O-ring

To replace the spade drive O-ring inside the meter:

1. Remove the meter cover by supporting the milk meter housing with both hands while pushing on the cover's ribs with your thumbs and rotating the cover counterclockwise. Then, remove the rotor.
2. Dry the inside of the meter thoroughly.

3. Turn the spade drive counterclockwise and remove it.
4. Carefully remove the O-ring and discard it.
5. Apply a thin film of Bou-Matic O-ring grease to the underside of the spade drive and new O-ring. If the bottom of the spade drive is grooved, replace it.
6. Seat the new O-ring in the appropriate groove, and reassemble the spade drive firmly in place (but do not overtighten it).
7. Wipe off any excess grease, making sure that the grease does not contact the meter's base.
8. Position the rotor inside the meter. Then, check the vent in the meter cover to ensure that it is open, and reassemble the cover to the meter.

### Replacing the Meter Motor Gearbox

To replace the motor gearbox beneath the meter:

1. Remove the O-ring and spade drive inside the meter. Refer to "Replacing the Spade Drive O-ring" instructions, found earlier in this section.
2. Remove the thumbscrew on the bottom of the motor cover, pull the cover down, and disconnect the cable.

#### Note

Always use two pliers to unplug the meter cable connectors, and be careful not to pull on the wires.

3. Remove the gearbox mounting screws, and lower the gearbox away from the meter base.
4. Install a new gearbox at the meter base, using the same mounting screws.
5. Inspect the sensor/meter connector on the milk meter cable for faulty or corroded electrical connections. If the pins are bent or corroded, replace them according to the instructions in literature #9P-435, *Milk Meter Motor and Sensor Replacement Instructions*.
6. Apply corrosion inhibiting grease to all connections before and after reconnecting.
7. Replace the O-ring and spade drive inside the meter. Refer to "Replacing the Spade Drive O-ring" instructions, found earlier in this section.
8. Check the meter's operation after reassembly. The meter rotor must turn counterclockwise when the float is lifted, and the display should record 0.6 lbs of production for each full revolution of the rotor. If the meter does not operate properly, recheck the wiring and ensure that the shutter does not rub on the hall effect sensor; erratic or double counting of production may result from rubbing.



Following the gearbox replacement, test the motor's current draw as explained in Section 7 under the "Every Six Months" maintenance check.

#### Replacing the Reed Switch

To replace the reed switch inside the meter:

1. Remove the thumbscrew on the bottom of the motor cover, pull the cover down, and disconnect the cable.

**Note**

Always use two pliers to unplug the meter cable connectors, and be careful not to pull on the wires.

2. Loosen the screw on the side of the float tube, and slide the reed switch assembly out of the tube.

**Note**

Always pull on the metal portion—never on the wires.

3. Insert the new reed switch into the float tube, and align the dimple in the reed switch tube with the setscrew hole in the float tube to ensure meter accuracy.
4. Secure the reed switch in place by reassembling the setscrew.
5. Inspect the cable connectors and apply corrosion inhibiting grease to them before and after reconnecting. Refer to "Replacing the Meter Motor Gearbox" instructions, found earlier in this section.
6. Tighten the motor mount screws, and reassemble the motor cover.

#### Replacing the Float

To replace the float inside the meter (see Figure 13):

1. Remove the upper hair pin and slide the float off the float tube.
2. Inspect the float tube for mineral and protein buildup, and clean the tube if necessary.
3. Position the new float on the float tube so that the magnets inside the float are at the bottom.

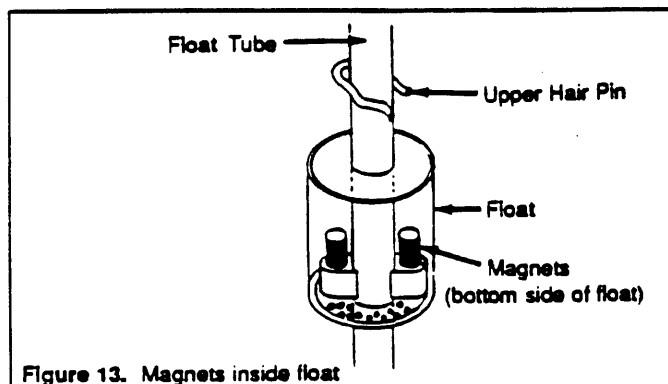

Figure 13. Magnets inside float

#### Replacing the Meter Motor & Sensor

To replace the motor or sensor or to repair corroded milk meter cable connections, refer to literature #9P-435, *Milk Meter Motor and Sensor Replacement Instructions*.

#### Replacing the Motor Mount

Remove the motor mount only when it is necessary to change the housing.

1. Remove the motor cover, motor gearbox, and reed switch.
2. Remove the two nuts and three screws that hold the mount in place. Grasp the 2 legs that support the motor and pull the motor mount away from the meter housing. The mount should snap away from the housing.
3. Seat the motor mount fully inside the lip on the new housing. Reassemble the reed switch and motor/sensor assembly, and tighten the fasteners to 70 oz ins of torque.

**Note**

Incorrect torque on these fasteners may result in inaccurate readings.

4. Reassemble the motor cover.

Once the meter has been reassembled, ensure that it is level. Then, water test it for accuracy according to the *Milk Meter Accuracy Test Instructions*, literature #9P-341.

## 4. DETACHER SYSTEM OPERATION

To better acquaint you with the detacher and aid you in monitoring its operation, this section provides an explanation of the detacher's features and functions.

### 4.1 Understanding the Detacher Assemblies

As mentioned in the introduction, the detacher consists of

- an electronic control and display,
- a milk meter,
- a pinchoff valve,
- a detach mechanism, and
- a hose support arm (optional)

#### Electronic Control and Display

The electronic control is responsible for monitoring the activity of the milk meter, the pinchoff valve, the detach mechanism, and the hose support arm, if used.

The control has been provided with two control buttons, the AUTO/MANUAL button and the ATTACH/DETACH button; two operation and activity indicator lamps, the MANUAL lamp and the NO MILK lamp; a keypad for selecting special functions; and three display windows labeled CODE, COW NO./DATA, and PRODUCTION.

By pressing the appropriate control button, the dairyman may use the detacher in either the automatic mode, which enables the detacher to determine when a cow is milked out and to remove automatically the claw from her udder, or the manual mode, which places the responsibility of monitoring a cow's milking onto the operator. When the manual mode is selected, the operator must manually detach the claw (as explained in "Understanding the Automatic & Manual Modes") from the cow's udder. The MANUAL and NO MILK lamps are visual indicators of the milking mode or activity taking place.

The CODE, COW NO./DATA, and PRODUCTION display windows provide the dairyman with such data as a cow's individual milk production, milking time, and cow number. In addition, certain detacher operation settings can be checked at the display. Data is grouped and available with the entry of a simple command at the detacher keypad.

#### Milk Meter

The Model "M" milk meter measures a cow's milk production, calculates milk flow to determine takeoff, and sends milk weights to an Agri-comp computer, if used.

The milk meter, as shown in Figure 14, consists basically of a meter housing, a spade drive, a rotor, a motor/sensor assembly, and a reed switch and float.

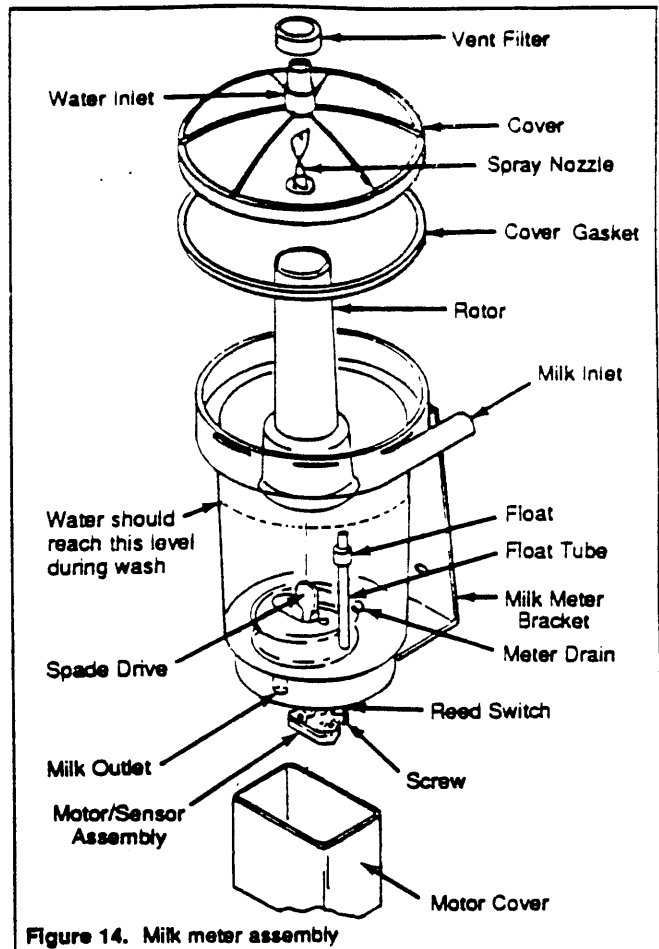

Figure 14. Milk meter assembly

As milk and air enter the meter from the claw (see Figure 15), they are separated; milk flows around the main chamber and down the inside walls (to minimize foaming), while air escapes through the center of the rotor. This separation allows the meter to maintain a stable vacuum level.

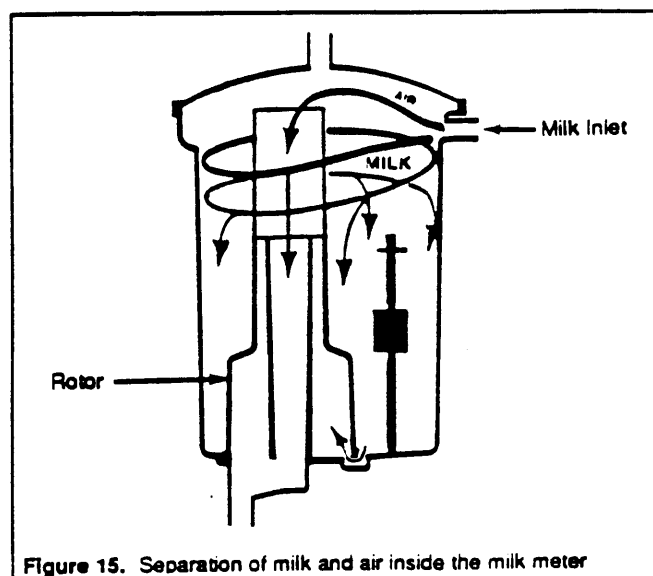

Figure 15. Separation of milk and air inside the milk meter

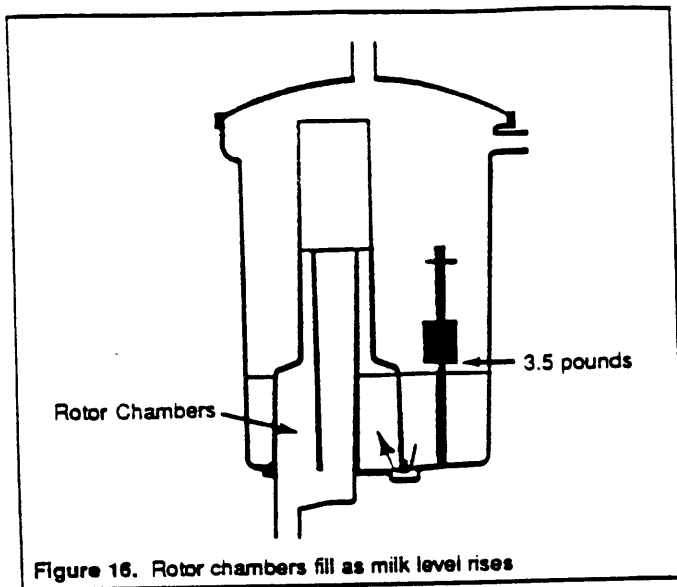

Figure 16. Rotor chambers fill as milk level rises

As the milk level rises within the main chamber (see Figure 16), the rotor chambers (located at the bottom of the rotor, and positioned over the filling trough in the meter housing) also fill. When the total amount of milk inside the meter exceeds 3.5 lbs (see Figure 17), the milk lifts the float, which causes the motor to turn the spade drive and rotor. This action causes each chamber to release a measured amount of milk into the milk line as the rotor moves over the meter's milk outlet. The meter continues to release milk until the level of milk inside the meter drops to 3.5 lbs, lowering the float.

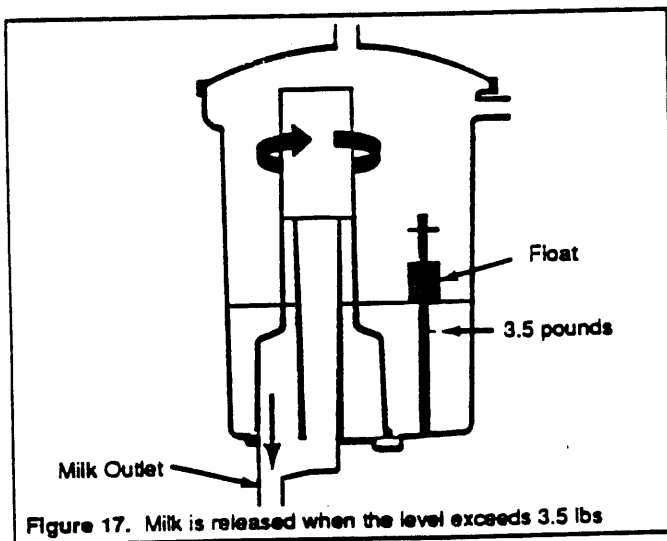

Figure 17. Milk is released when the level exceeds 3.5 lbs

With a small, toothed shutter (located on the rotor drive shaft and passing through the sensor's magnetic field), the meter can count the number of passes that the rotor chambers make over the milk outlet. This number calculated with the measured amount of milk is the method used by the meter to determine a cow's production. (See Figure 18.)

#### Pinchoff Valve

The pinchoff valve is an air-operated device, which, prior to detach, pinches the milk hose and completely shuts off vacuum to the claw.

#### Detach Mechanism

The detach (takeoff) mechanism is an air-operated retraction cylinder and link chain, which, when signaled by the electronic control at the end of milk flow, causes the claw to detach from a cow's teats. The chain retraction makes this detacher compact and lightweight compared to link-arm type detachers.

#### Hose Support Arm

The optional hose support arm, if installed, helps to maintain the proper milking unit position. This arm swings into position when the ATTACH/DETACH button is pressed and retracts out of the way when the milking unit is removed from a cow.

## 5.2 Understanding the Automatic & Manual Modes

The detacher may be operated in either the automatic mode or the manual mode by pressing the appropriate button on the electronic control.

When operated in the automatic mode, the detacher activates the milk meter to measure a cow's milk flow rate to determine when she is milked out. The milking unit will stay attached to the cow and continue milking as long as the milk meter measures a minimum flow rate (determined by the preset flow rate in sub-section 2.4.6.7). When the milk meter no longer measures the minimum flow rate, the detacher starts a preset takeoff delay, which allows the cow to reestablish milking (if she temporarily paused) before the milking unit detaches. *Note:* The 2101M comes preset with a 13-second takeoff delay (see sub-section 2.4.6.7 for information on selecting other possible delay settings). If the cow does not resume her milk flow before the delay time elapses, the detacher activates the air-operated pinchoff valve to shut off vacuum to the cow's teats. With vacuum shut off, the air-operated cylinder automatically retracts the link chain, gently detaches the milking unit from the cow, and retracts the hose support arm (if used).

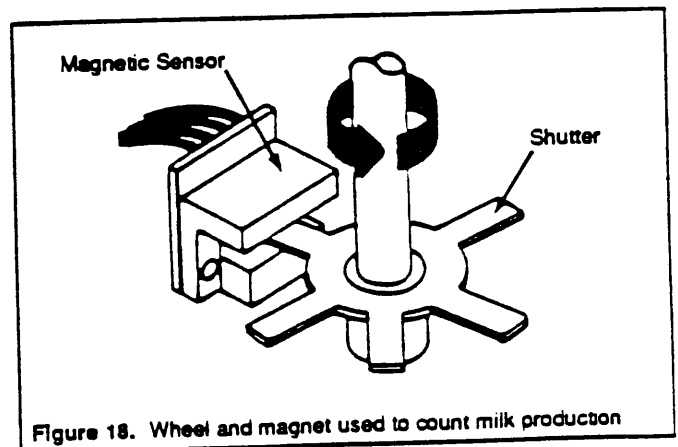

Figure 18. Wheel and magnet used to count milk production

Operating the detacher in the manual mode overrides detacher activation by milk sensing. As a result, the detacher cylinder will not retract and detach the milking unit from a cow unless the operator presses the appropriate control button.

The AUTO/MANUAL button is used for selecting either the automatic takeoff mode or the manual takeoff mode. When the detacher is set to the automatic takeoff mode, the lamp labeled MANUAL will be off. Conversely, when the detacher is set to the manual takeoff mode, the MANUAL lamp will be on.

The ATTACH/DETACH button, when pressed to begin each cow's milking, signals the detacher to release the milking unit (so that the unit can be attached to a cow), to open the milk valve, and to open the cow's production record. (Following initial powerup, as the button is pressed, the NO MILK lamp turns on, indicating that no milk is being sensed.)

#### **Automatic Mode—Early Detach (less than 2.2 minutes)**

To allow the operator enough time to attach the milking unit to a cow, the cow adequate time to let down her milk, and the meter to fill to 3.5 pounds, the detacher features an initial 2.2 minute (132 second) response time. From the moment that the ATTACH/DETACH button is pressed until the 2.2 minutes elapses, the detacher will not permit the milking unit to detach even if no milk is measured. And, if no milk is measured during the first 2.2 minutes, the NO MILK lamp will remain on constantly. Following the 2.2 minute response time, if no milk is measured, the milking unit will detach and the lamp will begin flashing. *Note:* A flashing NO MILK lamp indicates an early detach—the milking unit was attached to a cow for less than 3.0 minutes. The NO MILK lamp stops flashing when the operator reattaches the milking unit to the cow. In doing so, the operator must again press the ATTACH/DETACH button at the control.

#### **Automatic Mode—Early Detach (less than 3.0 minutes)**

If a cow gives milk consistently during the first 2.2 minutes but her flow temporarily pauses or drops below the preset flow rate within the 2.2 to 3.0 minute period, the NO MILK lamp will light constantly and the takeoff delay sequence will start. If the milk flow resumes and reaches or exceeds the minimum flow rate before the delay time elapses, the NO MILK lamp will automatically turn off and the detacher will reset its delay timer to zero. The lamp and delay process will repeat for each low flow rate condition a cow experiences as long as she resumes a minimum milk flow rate within the takeoff delay period. If at the end of the delay the cow does not resume a minimum flow rate, the milking unit will detach and the lamp will begin flashing—an early detach has occurred. Once again, to stop the NO MILK lamp from flashing, the operator must press the ATTACH/DETACH button and reattach the milking unit to the cow.

*Note:* Systems using an Agri-comp computer should operate the detachers with a 30-second dump delay to allow the

operator ample time to reattach the milking unit to a cow when an early detach occurs. Providing time for reattachment is important when you are using a computer, because the releasing of milk signals the computer to close the cow's production record. Upon reattachment, only the records of those detachers set with a 30-second dump delay will reopen to record additional milk production. (See sub-section 2.4.6.8 for more details.)

#### **Manual Mode**

While the 2.2 minute initial response and the 3.0 minute total response times occur in both the automatic and the manual modes, they are only apparent with the automatic mode since the manual mode overrides the detach function. If you are milking in the automatic mode and a cow detaches early, you may choose to finish her milking in the manual mode so that you can more closely monitor her activity. In this case you would press the AUTO/MANUAL button (the MANUAL lamp will light) and then the ATTACH/DETACH button to reattach the milking unit to the cow. Here again, the NO MILK lamp will stay lit until the minimum milk flow rate is measured.

When the cow is milked out, the NO MILK lamp will light constantly, but the takeoff delay sequence will not start. Also, the milking unit will stay attached to the cow and continue milking until the ATTACH/DETACH button is pressed (required only for manual takeoff of the milking unit). Pressing the button this time causes the detacher to detach. The NO MILK lamp remains on constantly (not flashing) until the operator attaches the milking unit to the next cow to be milked and the minimum milk flow rate is measured.

*Note:* Manual mode can be selected before attaching the milking unit or while in the automatic mode if you desire. Milk is measured and weights are recorded at the computer, if used. Whenever the ATTACH/DETACH button is pressed to detach a milking unit, the detacher unit automatically returns to the automatic mode once the meter finishes emptying milk.

#### **Automatic Mode—Normal Detach (more than 3.0 minutes)**

As defined earlier, an early detach is one in which the milking unit is attached to a cow for less than 3.0 minutes. This being so, a normal detach would be any that occurs beyond the 3.0 minute period.

When the cow's milk starts to flow and the amount of milk inside the meter becomes more than 3.5 lbs, the rotor starts to turn, releasing milk into the milk line, and the display begins to count production. Then, when her milk flow rate reaches or exceeds the minimum flow rate (0.7 lbs/min standard), the NO MILK lamp automatically turns off and remains off as long as the minimum flow rate is measured. Following the first 3.0 minutes, whenever a cow's low flow rate condition exists, the electronic control lights the NO MILK lamp constantly and starts the takeoff delay sequence. If by the end of the delay the milk flow does not resume or does not reach the minimum flow rate, the control signals the detacher to shut off vacuum and

detach the milking unit. Then, following a preset dump delay (either 30 seconds or 0 seconds after detach), the rotor turns to empty the remaining 3.5 lbs of milk left in the meter. Because this milk was counted at the start of milking, it does not get added at this time. The NO MILK lamp remains on constantly (not flashing) until the milking unit is attached to the next cow to be milked and the milk meter again measures milk.

If during a takeoff delay period a cow does continue her milk flow and it reaches or exceeds the minimum flow rate, the NO MILK lamp will automatically turn off and the detacher will reset its delay timer to zero. The lamp and delay process will repeat for each low flow rate condition a cow experiences as long as she resumes a minimum milk flow within the takeoff delay period.

### 5.3 Using the Keypad & Display

The detacher keypad can be used at any time to issue commands for setting values, performing actions, or recalling certain data. Installations using detachers without an Agri-comp computer are limited to recalling data only, however. (If you are using an Agri-comp computer, refer to the Agri-comp manual for information on the commands available.)

Three commands can be entered at the keypad to recall (view) data stored in the detacher:

- 0 # to display the cow number and production
- 1 # to display the time and production
- 2 # to display the flow rate and takeoff delay

Requested data will appear in the three display windows. The CODE window indicates which code parameter (0,1, 2, etc.) was selected to display data at the detacher. The COW NO./DATA window indicates the cow's number (if entered), the time (in tenths of minutes), or the milk flow rate depending on which command was entered. And the PRODUCTION window indicates the milk production or takeoff delay time depending on which command was entered. The following examples will better explain each command.

When you enter the command for "Cow Number and Production" at a detacher while it is in the attach mode, the detacher display should read:

Parameter	<input type="text" value="0"/>	<input type="text" value="0"/>	Cow No.
	<small>CODE</small>	<small>COW NO./DATA</small>	
		<input type="text" value="3.5"/>	Production
		<small>PRODUCTION</small>	

The "0" shown in the CODE window indicates the code parameter used to display data at the detacher. Specifically, 0 means *display cow number at attach*.

A "0" appears in the COW NO./DATA window of detachers not connected to an Agri-comp computer. The number of the cow being milked will appear in place of the zero if an Agri-comp is used.

The PRODUCTION window, showing an initial 3.5 pounds of milk, will begin incrementing in tenths of pounds (or kilograms) once the meter fills beyond 3.5 lbs and the rotor turns to release milk. The incrementing will stop each time a low flow rate condition exists and will continue each time the minimum flow rate resumes. Because the initial 3.5 lbs of milk is counted at the beginning of each milking, before the meter actually empties milk, the last 3.5 lbs is not counted.

Whenever you press the ATTACH/DETACH button to begin a cow's milking or you enter the command for "Time and Production" at a keypad (to return the detacher to its default setting after selecting another parameter), the detacher opens the cow's production record and the display should read:

Parameter	<input type="text" value="1"/>	<input type="text" value=".0"/>	Time
	<small>CODE</small>	<small>COW NO./DATA</small>	
		<input type="text" value="3.5"/>	Production
		<small>PRODUCTION</small>	

The "1" shown in the CODE window indicates the code parameter used to *display time since attach*.

".0", appearing in the COW NO./DATA window, is the milking time. This number will begin to increment in tenths of minutes immediately after you press the ATTACH/DETACH button, and it will stop incrementing when the milking unit detaches.

The PRODUCTION window for code parameter 1 displays the initial 3.5 pounds of milk and increments the increasing milk weight the same as it does for code parameter 0.

#### Note

The detachers' default setting of "Time and Production" can be changed at an Agri-comp computer, if used. (Refer to the Agri-comp manual for details on how to change the default setting.)

When you enter the command for "Flow Rate and Takeoff Delay" at a detacher while it is in the attach mode, the detacher display should read:

Parameter	<input type="text" value="2"/>	<input type="text" value=".7"/>	Flow Rate
	<small>CODE</small>	<small>COW NO./DATA</small>	
		<input type="text" value="13"/>	Takeoff Delay
		<small>PRODUCTION</small>	

Here again, the CODE window indicates the code parameter used to display data at the detacher—2 meaning *display flow rate at attach*.

The ".7" and "13", appearing in the COW NO./DATA and PRODUCTION windows, are the factory-set flow rate and takeoff delay settings, explained in section 2.4.6.7.

## 5.4 Using the Milking System

To set the milking mode and attach the milking unit to a cow, use the following procedure:

1. **Select the desired milking mode (automatic or manual) and check the lamps to ensure the proper selection.**  
The detachers automatically default back to the automatic mode after every detach, so you need not select this mode before milking each cow; however, it is a good practice to check that the MANUAL lamp is off. If the lamp is on, press the AUTO/MANUAL button to turn it off.

If you want to operate the detacher in the manual mode and the MANUAL lamp is off, press the AUTO/MANUAL button to turn it on.

2. **While holding the claw in your hand, press the ATTACH/DETACH button.**  
The detacher will release the claw and open the milk valve.
3. **Attach the claw's teat cups to the cow's teats.**
4. **Adjust the hoses in the hose support arm hook so that the claw is positioned properly under the cow.**  
The proper position is when the claw is parallel to the cow's center line.
5. **Lay the chain in the chain hook of the hose support arm.**  
Placing the chain there will keep it clear of the cow's legs.

Remember, if the milking unit was attached for more than 3.0 minutes (a normal milking), the NO MILK lamp will remain on continuously, in either mode, after detach. If the unit was attached in automatic mode for less than 3.0 minutes, the NO MILK lamp should flash after detach, indicating an early detach. When an early detach occurs, check the cow to determine the problem and correct it.

When each cow's milking is complete, the milking unit responds in the following sequence:

1. The display window showing "time" stops counting.
2. The pinchoff valve closes.
3. The air cylinder retracts, pulling on the chain, which detaches the claw and retracts the hose support arm.
4. The CODE window displays a "25," meaning *detach*.

### Note

The display will go blank and the lamps will power down if no buttons are pressed for 23 minutes. The display and lamps will resume normal operating brightness when any control button is pressed.

## 6. WASH SYSTEM OPERATION

Proper cleaning of your pipeline milking system is essential to eliminate bacteria and soils left in the lines and equipment after milking, which could cause milk spoilage or harm your milking equipment. For an explanation of the cleaning cycles involved in the cleaning process, refer to literature #9P-574, "Parlor Wash System."

### 6.1 Washing Milk Contact Surfaces

Wash the milk lines and milking units after every milking, using the following procedure:

1. **Set each detacher to the manual mode and press the ATTACH button.**  
The detacher will display a "1" in the CODE window and light the NO MILK and MANUAL lamps.
2. **Attach the claws' teat cups to the jettors and open the jetter wash valve.**
3. **Open the wash line valve above each meter.**
4. **Start the rinse and wash routine.**  
Refer to your washer instructions for details.

During the wash cycle, after 7 minutes of inactivity, the meter recognizes that it has been washed, and the rotor turns to empty any remaining water from the meter.

Just prior to the next milking, sanitize the lines and milking units according to your washer instructions.

### Note

When removing the meter cover during milking, rinse milk residue from the cover immediately upon removing the cover. Once milk settles behind the cover gasket, you will not be able to wash it out by clean-in-place (CIP) washing. Before reinstalling the cover, check to see that its vent hole is open.

### 6.2 Washing Non-Milk Contact Surfaces

As necessary, clean the outside of the electronic controls, hoses, and plastic assembly housings using a sponge and mild detergent, followed by a clear water rinse.

When cleaning a detacher, set it to the manual and attach modes, with the retraction chain fully extended, and leave power to the unit on while washing it. The heat generated by the electronic control when it is on helps to keep the detacher dry inside, which may extend the life of the electronic components in the control.

#### Caution

Do not use high-powered spray nozzles to clean the electronic control. Water could enter the enclosure and damage the electronic components.

#### Caution

Certain materials contain ingredients which will attack the detacher's plastic assembly parts. Do not expose the plastic parts to any of the following:

- Fly sprays
- "Super" glues
- Gasoline, turpentine, brake fluids; and ethers
- Refrigerants
- Loctite and similar adhesive compounds
- Phosphate
- Bou-Matic manual cleaner
- Phenols
- Alcohol, ethanol, and isopropanol

In addition, use of cleaners other than those recommended by Bou-Matic and excessive concentrations of those that are recommended is not advised.

Use of non-recommended chemicals will be done at the owner's risk, and damages to the plastic parts resulting from improper cleaning will nullify any warranty covering those parts.

## 7. MAINTENANCE

To aid you in monitoring your detacher system, we recommend that the items in this section be checked for cleanliness, wear, and replacement at their specified intervals.

*Remember, you, the dairyman, are responsible for monitoring the detachers to ensure that they are functioning properly.*

#### Weekly

Drain the air compressor tank and the air line moisture trap once a week. Failing to do so will reduce the effective volume of the tank and shorten the life of the air compressor. In addition, water in the air lines can adversely affect detacher operation. Also, check the vent hole filter to ensure that the vent hole is open.

#### Every Two Weeks

Check the meter for cleanliness to ensure proper float and drain operation.

#### Monthly

Check the air line filter for dirt and water at least once a month. If the pre-filter element is dirty, wash it out. If the coalescing filter element is dirty, you must replace it with a new element.

#### Every Three Months

Replace the hose inside the pinchoff valve every three months, sooner if it no longer opens fully with air pressure off or no longer closes fully with air pressure on.

Check the rubber on the meter rotor base. If it is torn, grooved, or separated, replace the rotor.

Lubricate the O-ring located under the meter spade drive with Bou-Matic O-ring grease.

#### Every Six Months

During scheduled service on the milk meters after O-rings have been replaced and lubricated, check the motor's condition by measuring the current required to turn the spade drive.

Using a digital meter with a milliamp test cable (available from Bou-Matic) connected in series between the detacher and meter cable, measure the motor's current using the following procedure:

1. Remove the meter cover and rotor.
2. Open the detacher cover and unplug the connector labeled "Meter" on the electronic control.
3. Plug one connector of a millilamp test cable into the connector on the control—plug the other test cable connector into the connector on the meter cable.
4. Set the digital meter to DC-mA range 200 mA, and plug the opposite end of the test cable into the meter.
5. Lift the float and allow the motor to wind up to a consistent speed.
6. Check the motor's current on the digital meter. The current should be less than 150 mA. If it is above 150 mA, check to make sure that the motor is mounted properly. If mounted properly and current is still over 150 mA, then the motor or gear box should be replaced.

#### Yearly

In addition to replacing some of these at other intervals, replace the following parts on a yearly basis:

- The O-ring under the meter spade drive
- The meter drain valve
- The meter cover gasket

#### Note

Examine the meter cover gasket before installing it in the cover; note that one lip (upper lip) of the gasket is slightly longer than the other (side lip). Holding the cover upside-down, seat the gasket upper lip down on the ridge below the cover's locking tabs. At first the gasket will seem too big and will buckle, but it will eventually snap into place. Ensure that the gasket is properly seated by pressing its side lip against the outside wall of the cover.

#### Miscellaneous

Use Bou-Matic lamp bulbs when replacing burned out lamps in the electronic control. Electronic failures may result if other types are installed.